

R-450M ROUTER MACHINE

VECTRON TECH





CONTENT

1

Equipment introduction

2

Device features

3

Equipment advantages

4

After-sales service

5

What to solve customer problems



R-450M ROUTER

- **Modular design, flexible and stable**
- **Reserve extended space for post-unmanned operation**
- **Fixed vacuum design, good vacuuming effect**
- **Internal vacuum cleaner saves space**
- **Intelligent management consumable system**

Machine Informations

- Machine size: 650L*1250W*1350H (mm)
- Table size: 390mm*560mm
- Max PCB size: 310mm*480mm
- Monitor: DELL, 17"

Optional items

- 1、bottom vacuum
- 2、 External vacuum system 5P
- 3、 iRoz nozzle
- 4、 Broken knife monitoring

R-450M ROUTER



Fast Cutting Speed

- Specially designed for high quality production, high-speed driving platform with high-speed spindle bring the customer to another level of lean and efficient production, it provides the solution for the customer in PCB separation and become the market leader in the industry.

High Precision Vision System

- High-pixel CCD camera provide auto position correction features during the machine operation to provide high precision cutting result to the customer to full the customer expectation of high quality production.

Lost Cost Production

- R-450M come with tool life management monitoring tools, with the parameter set, the R-450M automatically move the Z position to fully utilize the router bit to ensure the cutting quality and reduce the operation cost of the production by prolong the life span of the router bit.



R-450M ROUTER

Powerfull Internal/External Vacuum System Optional

- R-450M comes with can remove dust collection/suction system,it provides the better dust removal capability during the board separation process; the design is compact and provides low noise production;energy consumption is 50% lower compare to the similar equipment in the market;the compact design of the machine also provide the flexibility of the location of the machine with limited production space.

Self-Diagnostic Function

- R-450M come with self-diagnostic function for easier machine troubleshooting to reduce the machine downtime,it will able to resume the production promptly.

Simple Interface, Free Software Update

- Vectron self-developed control system with users-friendly interface;simple programming,short change over time,imporved production efficiency,lifetime free software update.

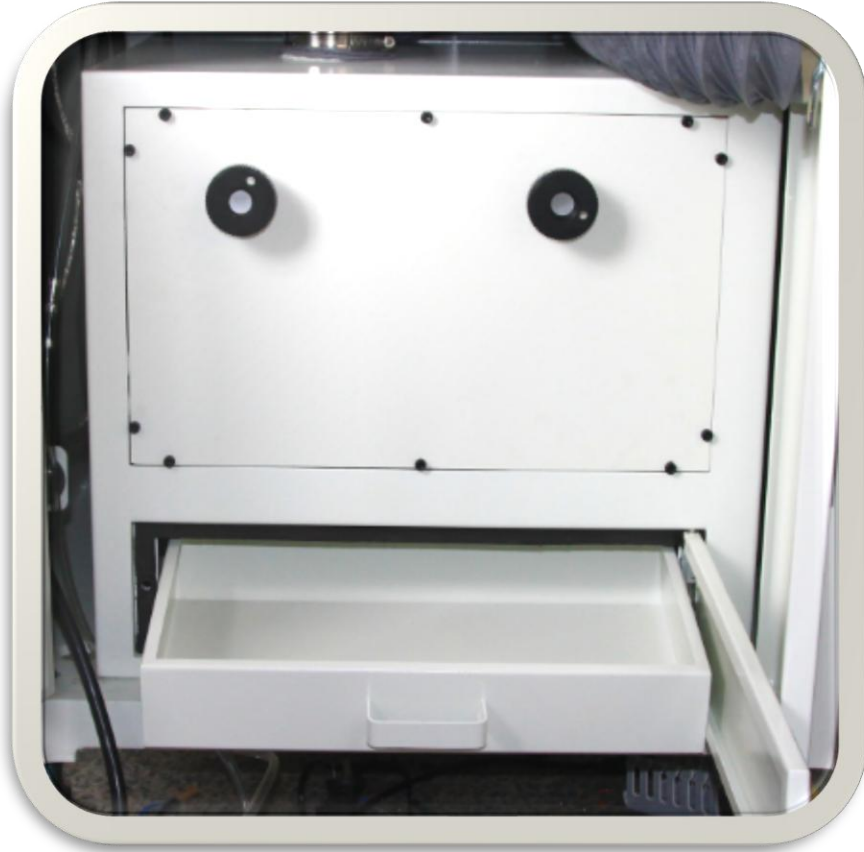

R-450M ROUTER

Vacuum suction device under negative pressure, built-in integrated, efficient and clean solution to vacuum problems

- The negative pressure type vacuuming structure is adopted, and the air outlet is located under the carrier fixture. Make a negative pressure inside the fixture, and easily remove the dust generated when the cutting board is cut; The drum type dust removal structure is built into the bottom of the machine, which perfectly solves the cutting board. Dust trouble, reaching a small space, low noise production, lower energy consumption 1/2 of the same type of equipment saves limited production space in the workshop.

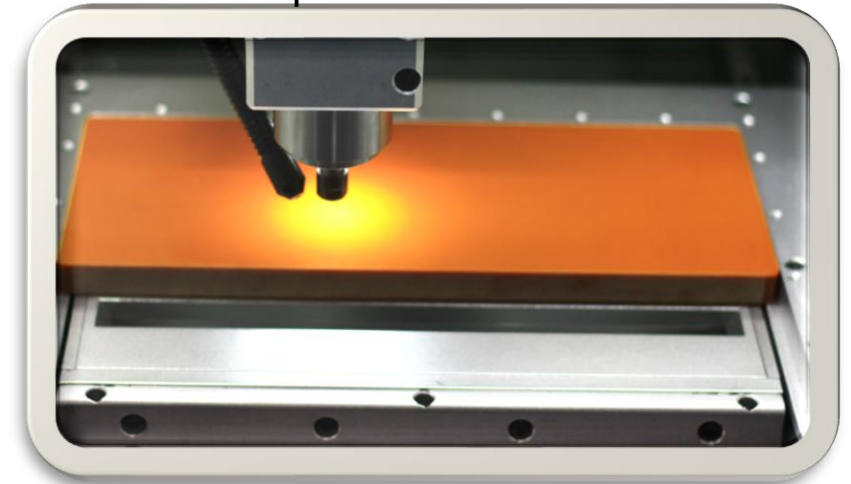

- The vacuum design of the Table and the dust suction point is point-to-point, the suction is more concentrated, and the dust is better.

R-450M ROUTER

- Modular electronic control system, quick troubleshooting, convenient equipment maintenance and upgrade



- Modular servo control system with high stability and cutting accuracy of $\pm 0.01\text{mm}$, meeting various cutting requirements and ensuring production quality

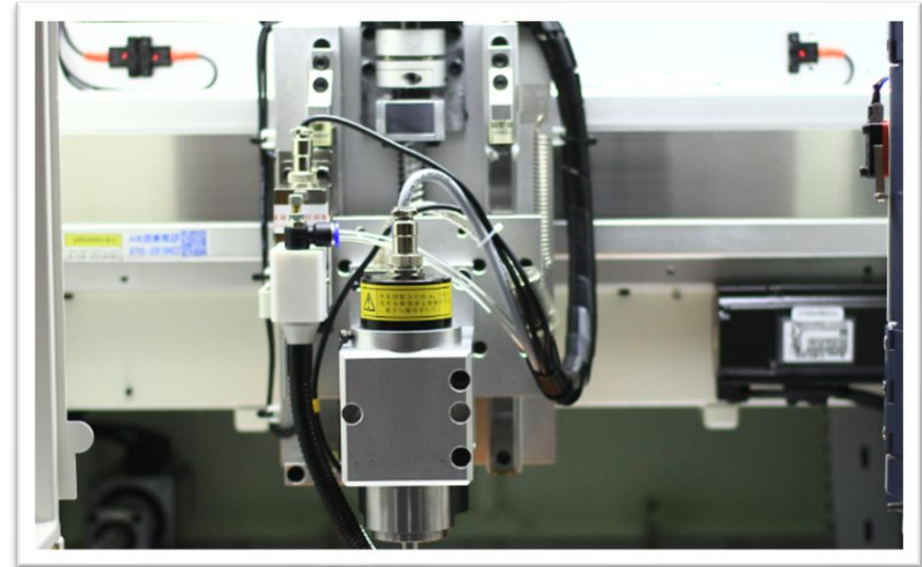

R-450M ROUTER



- The whole machine does not need an external exhaust duct, and does not occupy the fixed space of the factory.
- The device can be flexibly moved to match different line bodies



R-450M ROUTER

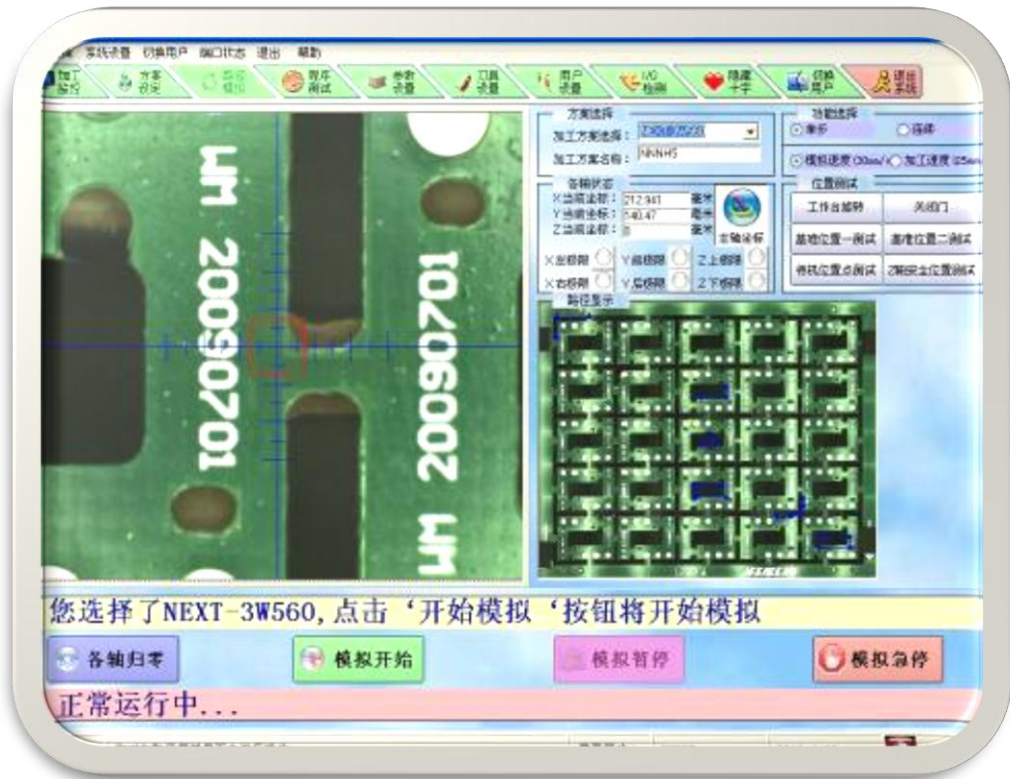

- Self-developed control system, humanization User operation Interface, free software upgrades
- Teaching programming, changeover time is short, improve production efficiency.
- There are certain basic computer operations staff through simple training to operate this machine independent.



Double Modules Match Advantage

- Double systems double machine, can independent work, reduce waiting times, Output by more than 60% higher than traditional double Table.
- One person can operate two devices at the same time, reduce labor costs, play the biggest role with the labor and equipment.
- Each module work independently, may require the production of different types of boards are based on production, one module fails, the other module can be work as usual, put an end to traditional equipment failure resulting in a single table the whole situation can not produce.
- As part of the product output cut, double module can be divided into two parts, each production, improve the flexibility of using equipment put an end to the traditional point machine on the production of waste.

R-450M ROUTER

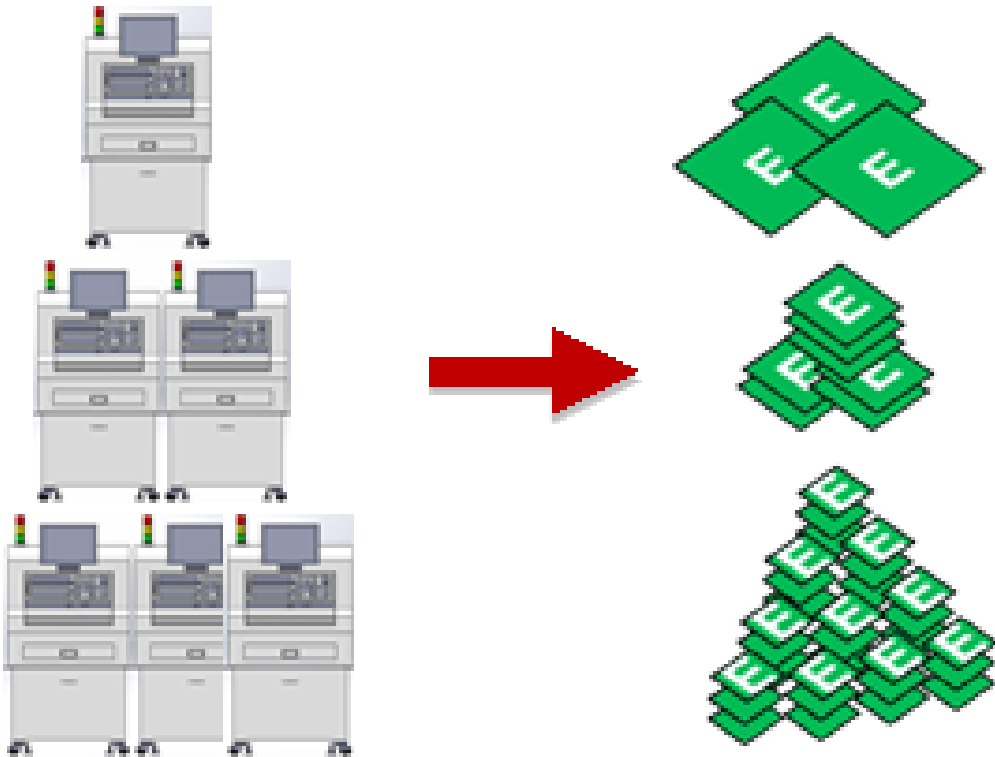

- According to the production needs of the factory, multiple modules can be used together, and the overall optimization can reduce the waiting time to ensure that the pick-and-place time is perfectly matched with the cutting time;
- Customers can increase the number of modules according to the output, reduce the up-front investment, and optimize the efficient operation of the plant.

R-450M ROUTER + ROBOT



R-450M ROUTER + ROBOT



R-450M ROUTER MACHINE

WWW.VECTRON-TEK.COM

R-450M ROUTER

Machine Size

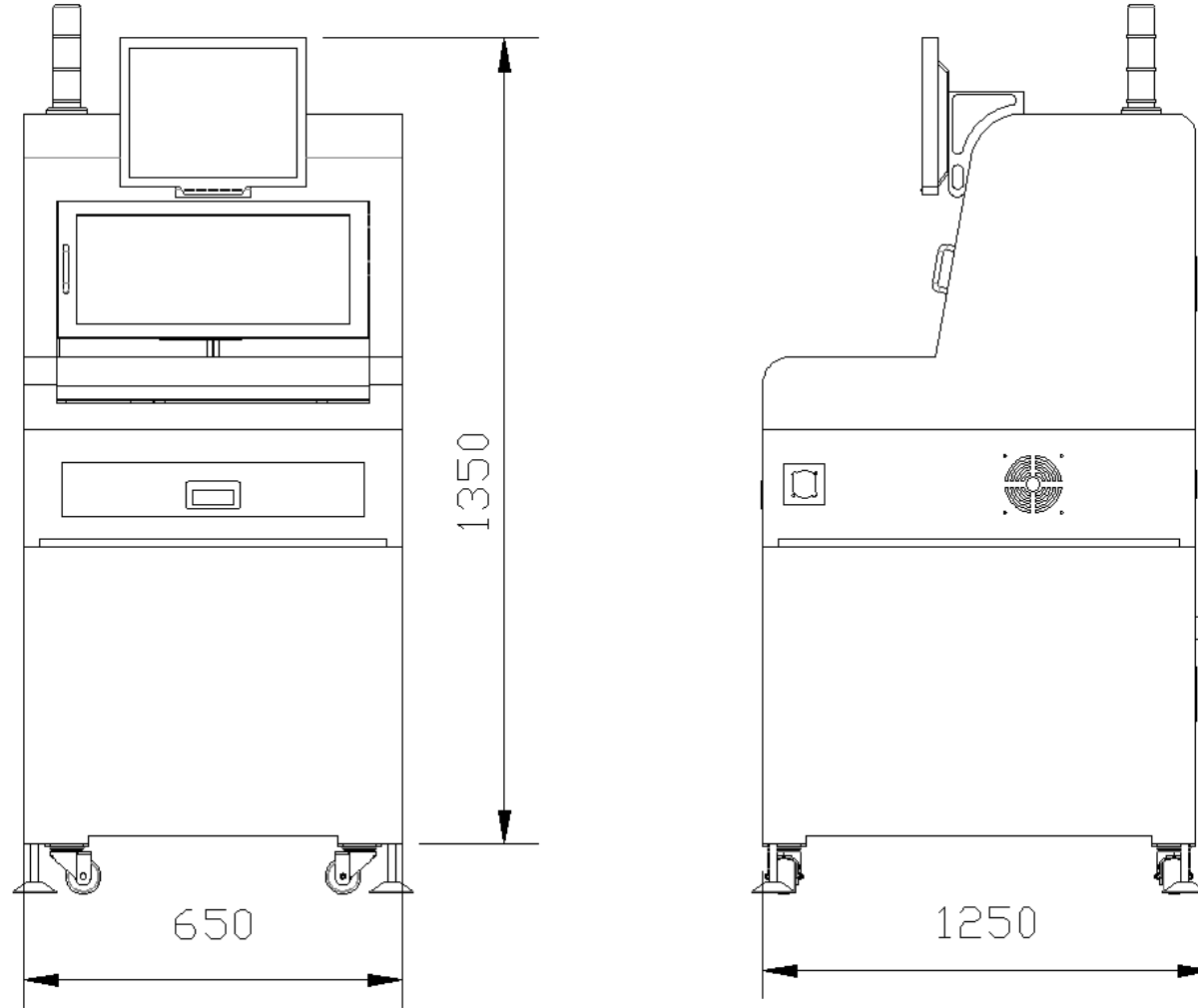

R-450M ROUTER

Notes:

Spec Form

Material	Milling cutter Range (mm)	Min product gap(mm)	Jig Installed
Nomal PCB	Φ0.8-Φ3.0	1.0	Suggested
Aluminum PCB	Φ1.8-Φ3.0	2.0	Suggested
Iron PCB	Φ1.8-Φ3.0	2.0	Suggested

谢谢观看!
Thanks!