

# Atmospheric plasma cleaner AP-100 operation instruction



JIT INDUSTRIAL VIET NAM COMPANY LIMITED

TEL: (84) 348 100 358

URL:[jit-asia.com](http://jit-asia.com)

## Catalogue

I. Product introduction .....	2
1.1 the principle of plasma cleaning .....	2
1.2 Function of plasma cleaning .....	2
1.3 Advantages of plasma cleaning .....	3
1.4 plasma cleaning structure .....	4
1.5 the characteristics of plasma cleaning .....	4
1.6 Application of plasma cleaning .....	4
II. Warranty period and service scope .....	5
2.1 Warranty Period .....	5
2.2 scope of services .....	5
III. Equipment specifications .....	6
IV. The overall size .....	6
V. Description of equipment appearance .....	6
VI. Equipment switch operation .....	9
6.1 boot operation .....	9
6.2 Shutdown operation .....	9
VII. Description of Touch Screen Interface .....	8
7.1 Description of function buttons .....	8
7.2 Description of functional parameters .....	8
7.3 signal input instructions .....	9
7.4 Description of alarm status .....	9
7.5 Description of other parameters .....	10
7.6 Description of power parameters .....	10
VIII. Description of Remote Communication Interface .....	12
8.1 Description of Remote Interface Wiring .....	12
8.2 Description of Remote Interface Communication .....	12
IX. Nozzle maintenance .....	15
X. Prevention and elimination of common faults .....	16

## I、 Product introduction

### **1.1 Principle of plasma cleaning**

AP-100 is an amplified current and voltage used in high-frequency and high-voltage transformer, which generates an arc by discharging between the electrode and the grounding discharge head. The generated arc makes air (or special gas) in a plasma state (mixed ions and electrons); At this time, compressed air or gas is injected, and the plasma generated by the nozzle of the discharge head is blown out; Functional equipment that can efficiently treat the surfaces of various materials.

### **1.2 Function of plasma cleaning**

#### **(a) Etching action on material surface-physical action**

A large number of ions, excited molecules, free radicals and other active particles in the plasma act on the surface of the solid sample, which not only removes the original pollutants and impurities on the surface, but also produces etching, roughening the surface of the sample, forming many tiny pits and increasing the specific surface of the sample. Improve the wettability of solid surface.

#### **(b) activation of bond energy, crosslinking**

The energy of particles in plasma is 0~20eV, while the energy of most bonds in polymer is 0~10eV. Therefore, after the plasma acts on the solid surface, the original chemical bonds on the solid surface can be broken, and the free radicals in plasma form a network-like cross-linked structure with these bonds, which greatly activates the surface activity.

#### **(c) Formation of new functional groups-chemical action**

If reactive gas is introduced into the discharge gas, complex chemical reactions will occur on the surface of activated materials, and new functional groups, such as hydrocarbon groups, amino groups, carboxyl groups, etc., are introduced, which can obviously improve the surface activity of materials.

### **1.3 Advantages of plasma cleaning**

As an important surface modification method, plasma cleaning has been widely used in many fields. Compared with some traditional cleaning methods, such as ultrasonic cleaning and UV cleaning, it has the following advantages:

#### **(a) low treatment temperature**

The treatment temperature can be as low as 50°C, and the low treatment temperature can ensure that the surface of the sample will not be affected by heat.

#### **(b) the whole treatment process is pollution-free**

Plasma cleaning machine itself is a very environmentally friendly equipment, which does not produce any pollution, nor does the treatment process produce any pollution. It can be matched with the original production line to realize full-automatic online production and save labor costs.

#### **(c) the treatment effect is stable.**

The treatment effect of plasma cleaning is very uniform and stable, and the effect remains good for a long time after conventional sample treatment.

#### **(d) auto production line can be perfectly matched to improve production efficiency.**

According to the user's on-site demand, the optimal assembly line production scheme is configured, which greatly improves the production efficiency.

### **1.4 Plasma-cleaned structure**

---

The structure of plasma cleaning machine is mainly divided into three parts, namely, high-voltage excitation power supply, plasma generator spray gun and control system.

**(a) High voltage excitation power supply:**

The generation of plasma needs high-voltage excitation, and the atmospheric low-temperature plasma is excited by an intermediate frequency power supply with a frequency of 40KHz. The high voltage is 4-10KV. The parameters can be adjusted according to the actual situation of the sample, and the optimal modification effect has been achieved.

**(b) plasma generator spray gun:**

The spray gun of atmospheric low-temperature plasma generator can be divided into two types: jet direct injection and rotary direct injection, the difference is that the treatment area is different.

**(c) control system:**

The function of the control system is to control the operation of the whole atmospheric low-temperature plasma cleaning equipment and the protection of the whole system.

## **1.5 Characteristics of plasma cleaning**

**(1) Full-bridge digital circuit technology:**

Full-bridge digital high-voltage excitation power supply circuit technology is adopted to generate high-density plasma to ensure stable cleaning effect.

**(2) Comprehensive safety protection:**

Temperature safety protection function, overload protection function, air pressure abnormality protection function, and various misoperation protection functions.

**(3) Unique discharge technology:**

Unique discharge structure ensures stable and uniform low potential plasma output and prevents electrostatic damage of products.

**(4) High-quality product parts:**

All parts of the product adopt top quality parts at home and abroad to ensure the stable use of the equipment.

## **1.6 Application of plasma cleaning**

Suitable for a variety of processes: according to customer needs, we can carry various automation platforms and select various spray guns to adapt to various product treatments.

- (A)** Improve the adhesion ability of the surface, and improve the reliability and durability of surface bonding.
- (B)** Treatment of needle and plastic catheter before adhesion in medical device industry.
- (C)** Activation: greatly improve the wettability of the surface and form an active surface.
- (D)** Cleaning: remove dust and oil, fine cleaning and static electricity.
- (E)** Coating: A functional surface is provided by surface coating treatment.
- (F)** After atmospheric air plasma treatment, the surface energy of all kinds of polymer plastics, ceramics, glass, PVC, paper and metal can be improved. Through this treatment process and the improvement

of surface tension characteristics of product materials, it is more suitable for industrial coating, bonding and other treatment requirements.

- (G) For example, in electronic products, LCD coating treatment, oil-jet screen printing on the surface of structural parts such as casing and buttons, glue and dirt removal and cleaning on PCB surface, and treatment before lens glue sticking, etc.
- (H) Pre-bonding treatment of automobile lampshade, brake pad and door sealing strip; Fine and harmless cleaning treatment of metal parts in machinery industry & treatment before lens plating and sealing between various industrial materials.
- (I) In the printing and packaging box pasting machine, the treatment before gluing the edge sealing position is carried out.

## II. Warranty period and service scope

This equipment has been debugged and checked to be OK before leaving the factory. Our company will guarantee it if it is used within the following conditions.

### 2.1 Warranty Period

This equipment is one year after leaving the factory.

### 2.2 scope of services

During the warranty period, the company will repair the faults caused by normal use free of charge, but the following situations will not be covered by the warranty.

Use consumables and components not specified by the Company.

Improper use or maintenance by the operator.

Normal consumption of consumables.

Other natural disasters.

The color of the equipment shell naturally fades.

Changes of heating and noise without affecting the normal operation of the equipment.

Suggestion: If you have any questions you don't understand in the actual process, please check the instruction manual or contact our engineering staff.

## III. Specification of equipment

System standard fittings	
Equipment size	576 mm(L) ×232 mm(W)×373mm( H)

Weight	20KG
Input power supply	220V, 50/60Hz
Power	500/
High voltage frequency	40KHz
Working gas	Anhydrous oil free compressor air: optional, nitrogen and soon.
Protection	Overload protection, short circuit protection, open circuit protection, temperature protection.
Remote control	Both local control and remote control can be used.
Spray gun selection	
Rotary spray gun	Processing width and diameter: $\Phi 80\text{mm}$ , $\Phi 60$ , $\Phi 40$ and $\Phi 20\text{mm}$ are optional.
Direct injection spray gun	Treatment width and diameter: 2, 3, 5mm 3m, Customizable.
Cable length	



Spinning nozzle for main chassis shape

## IV. Machine dimension

### 4.1 Chassis size: (unit: mm)

单位: mm

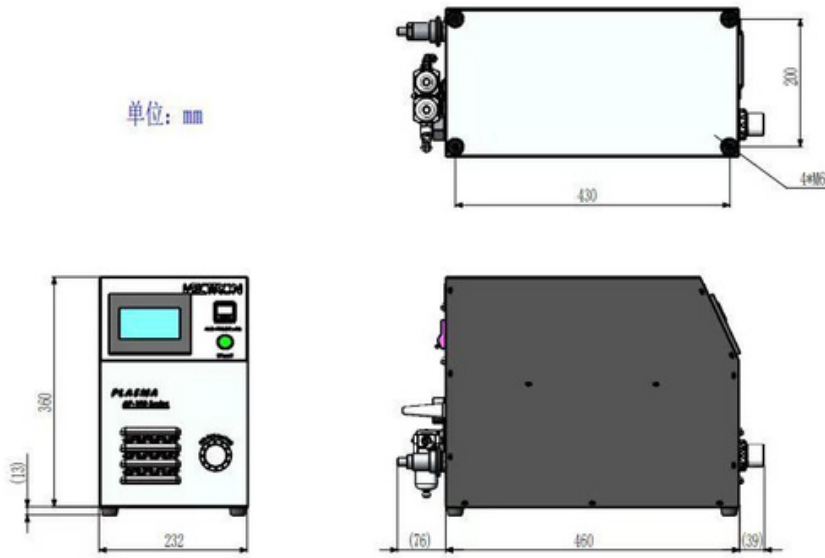

**4.2 Gun head size: (unit: mm)**

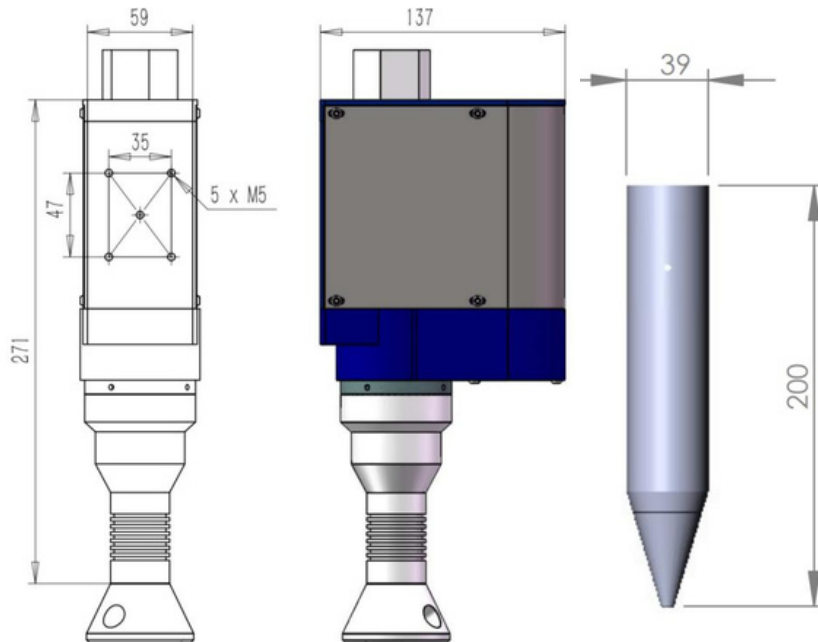

Rotary nozzle direct nozzle

**V. Description of equipment appearance**

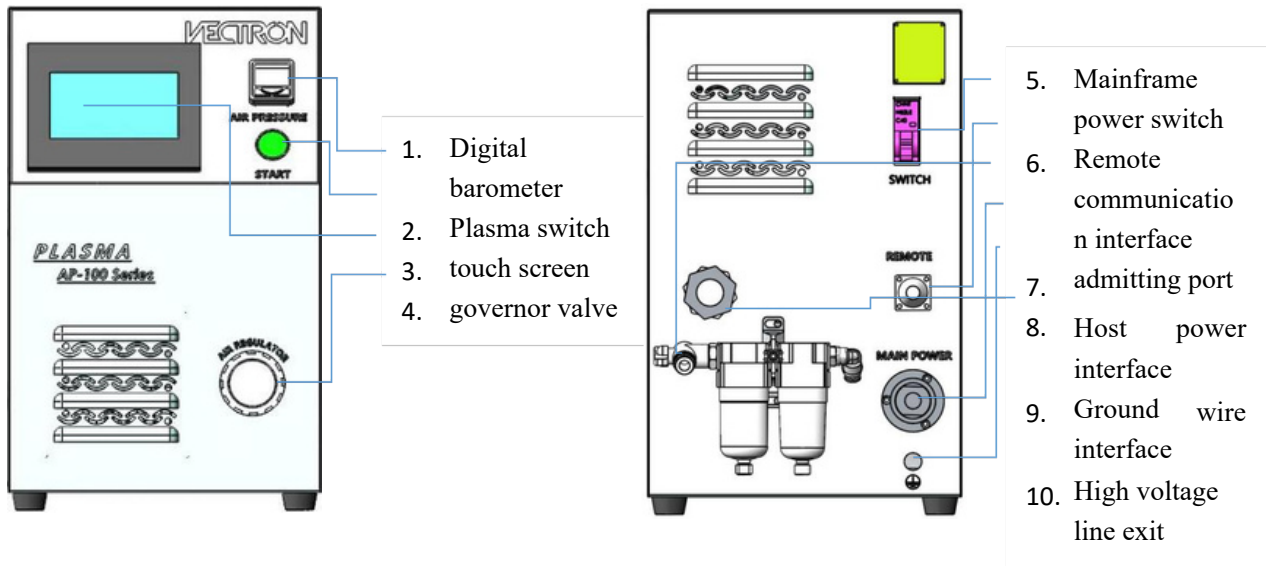

- Digital barometer: it is used to monitor whether the air pressure meets the requirements of the equipment (0.18 ~ 0.3 MPa), otherwise it will give an alarm.
- Plasma switch: Turn the plasma on and off.
- Touch screen: used for operation and data input or display.
- Air pressure regulating valve: used to regulate the input air pressure to meet the use requirements of the equipment, and observe the barometer to adjust the size.
- Mainframe power switch: Turn on and off all the power of the equipment.
- Remote communication interface: the communication port for RS485 data interaction or remote control signal between this equipment and other equipment.
- Air inlet: the air source required for equipment operation, and the standard air pressure is 0.4 MPa.
- Mainframe power interface: The standard input of this equipment is single-phase 220V AC.
- Ground wire interface: connect this equipment to the ground wire of the distribution box alone, and do not connect it in series with other equipment.
- High-voltage line outlet: the high-voltage line inside the nozzle is output from this position.

## VI. On-off operation of equipment

### 6.1 boot operation

(1) Before starting the machine, please confirm that the equipment has been correctly connected to the power supply and air supply, and the plasma spray gun is fixed and connected to the protective ground wire (warning: it is forbidden to start the machine if there is no ground wire);

(2) Turn on the power switch at the back of the equipment (pull it up). At this time, check whether the air pressure is normal (normal range: 0.18 ~ 0.3 MPa), otherwise, adjust the valve to make the air pressure reach the normal range;

(3) After the system self-check, the touch screen interface will be displayed as shown in the following figure;

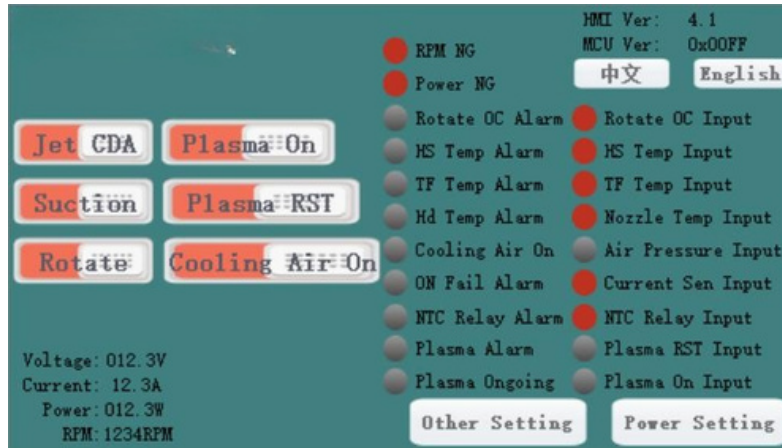

(4) Press the plasma switch in front of the equipment, and the plasma will work normally.

## 6.2 Shutdown operation

- (1) Press the plasma switch on the front of the equipment, and the plasma will stop working.
- (2) Turn off the power switch at the back of the equipment (pull it down), and then cut off the air supply of the equipment, at which time the equipment is shut down.

## VII. Touch screen interface description

After the device is powered on, the touch screen displays the following interface:



### 7.1 Description of function buttons

- (1) Start the plasma: this is a set of coherent actions, first turn on the externally controlled air injection and air extraction, at the same time start the nozzle to rotate, and then turn on the plasma. The same function as the plasma switch in front of the machine.
- (2) Plasma reset: clear all alarms of plasma and reinitialize.
- (3) Nozzle rotation: Turn the nozzle rotation on or off manually.
- (4) Air injection: manually open the air flow of the nozzle controlled by the external solenoid valve, with the function of delayed closure.
- (5) Air extraction: manually start the external air extraction system, with the function of delayed closing.
- (6) Turn on the cooling gas: manually turn on the cooling gas system of the external nozzle. This function is automatically turned on when the plasma is turned off.

### 7.2 Description of functional parameters

- (1) Voltage: displays the actual voltage value of single-phase alternating current when the equipment works.
- (2) Current: Displays the actual current value when the equipment works.
- (3) Power: Displays the actual power value when the equipment works.
- (4) Rotational speed: Displays the number of revolutions per minute of the plasma nozzle.

### **7.3 signal input instructions**

- (1) Rotating over-current input: the current set by the rotating motor is exceeded due to the unsmooth rotation of the nozzle and other factors, thus triggering the alarm signal input.
- (2) Heatsink temperature input: the temperature switch of the heatsink on the control panel exceeds the rated temperature, thus triggering the alarm signal input.
- (3) Transformer temperature input: the temperature switch on the transformer exceeds the rated temperature, thus triggering the alarm signal input.
- (4) Nozzle temperature input: the temperature switch on the nozzle exceeds the rated temperature, which triggers the alarm signal input.
- (5) Air pressure input: the actual air pressure input by the machine is not within the range set by the digital barometer, thus triggering the alarm signal input.
- (6) Current induction input: the plasma exceeds the set current during operation, thus triggering the alarm signal input.
- (7) NTC bypass input: NTC thermistor bypass function fails to trigger alarm signal input.
- (8) Plasma reset input: the status takes effect when the reset button of the touchscreen is pressed or the plasma reset is remotely controlled.
- (9) Start plasma input: press the plasma switch on the machine panel or remotely control the plasma to start, and the state will take effect.

### **7.4 Description of alarm status**

- (1) Abnormal rotating speed: When the rotating nozzle is turned on for rotating speed monitoring, if the actual rotating speed of the nozzle is not within the set range, the system will give an alarm. The direct nozzle can't start the speed monitoring, otherwise the system will give an alarm and stop working.
- (2) Abnormal power: When the machine is equipped with power monitoring and turned on, if the actual power of the machine is not within the set range, the system will give an alarm and stop working.
- (3) Rotating over-current alarm: If there is an abnormal signal of rotating over-current input during plasma operation, the system will give an alarm and stop working.
- (4) Heatsink temperature alarm: If an abnormal signal of heatsink temperature is input during plasma operation, the system will give an alarm and stop working.
- (5) Transformer temperature alarm: If an abnormal signal of transformer temperature is input during plasma operation, the system will give an alarm and stop working.
- (6) Nozzle temperature alarm: If an abnormal signal of nozzle temperature is input during plasma operation, the system will give an alarm and stop working.
- (7) Air pressure alarm: If an abnormal signal of air pressure is input during plasma operation, the system will give an alarm and stop working.
- (8) Current-induced alarm: If there is an abnormal current-induced signal input during plasma operation, the system will give an alarm and stop working.
- (9) NTC relay alarm: If the signal input of the relay is triggered when the NTC bypass function fails during the plasma start-up, the system will alarm and stop working.

- (10) Plasma alarm: In case of any of the above alarms during plasma startup or work, the system will temporarily store the alarm status and output signals to external devices.
- (11) During plasma operation: During normal plasma operation, the system outputs signals to external devices.

Note: When the machine has an alarm, stop using the plasma first, then investigate the cause of the alarm and solve it, and then reset the plasma to eliminate the fault before starting the plasma system.

### 7.5 Description of other parameters

Click the "Other Parameters" button in the lower right corner of the main interface to enter the following interface:



- (1) Upper limit of rotating speed: set the upper limit of the alarm of rotating speed of the nozzle per minute. If the actual speed exceeds this value and the speed monitoring function is turned on, the system will prompt that the speed is abnormal and stop working.
- (2) Lower limit of rotating speed: set the lower limit of the alarm of rotating speed of the nozzle per minute. If the actual speed is lower than this value and the speed monitoring function is turned on, the system will prompt that the speed is abnormal and stop working.
- (3) Hysteresis time: the reaction time of system alarm delay when the actual rotating speed of the nozzle is not within the upper and lower limits of the set rotating speed alarm.
- (4) Signal number: the number of signal that triggers the speed sensor when the nozzle rotates once.
- (5) Speed monitoring: whether the function of speed monitoring is turned on or not, and "NO" means on; "OFF" means off. The straight nozzle cannot turn on this function, otherwise the system will give an alarm.
- (6) Direct injection/rotary injection: select the type according to the gun head actually installed in the machine.

### 7.6 Description of power parameters

Click the "Power Parameter" button in the lower right corner of the main interface to enter the following interface:

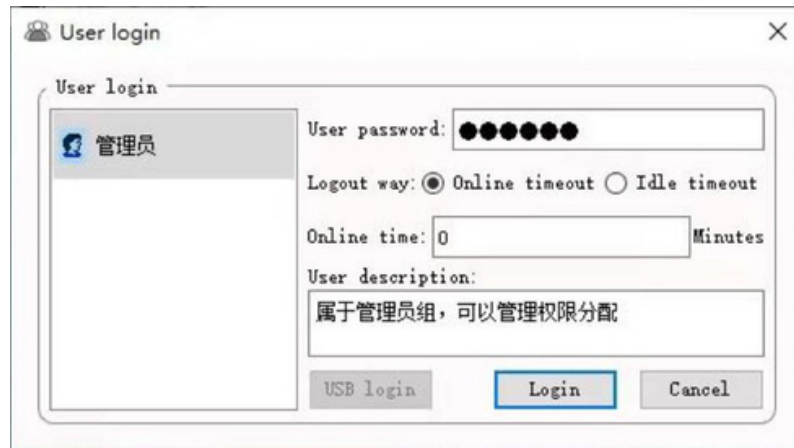

Enter the user password: 111111, click OK, and then click the Login button to enter the following interface:

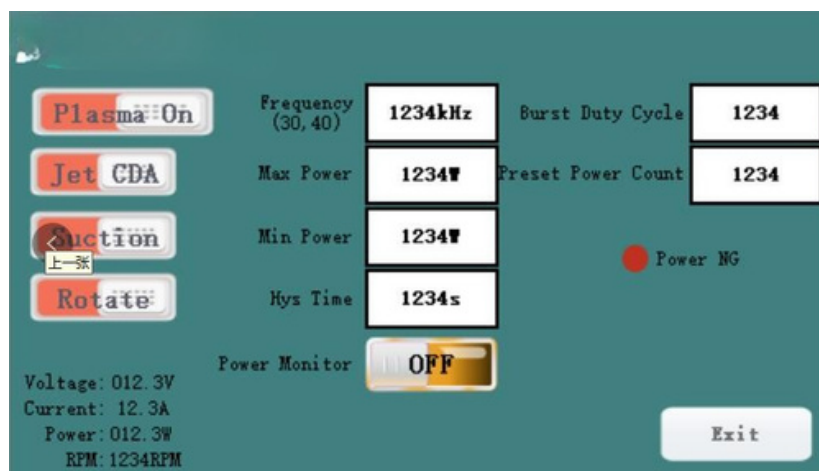

- (1) Start the plasma: this is a set of coherent actions, first turn on the externally controlled air injection and air extraction, at the same time start the nozzle to rotate, and then turn on the plasma. The same function as the plasma switch in front of the machine.
- (2) Nozzle rotation: Turn the nozzle rotation on or off manually.
- (3) Air injection: manually open the air flow of the nozzle controlled by the external solenoid valve, with the function of delayed closure.
- (4) Air extraction: manually start the external air extraction system, with the function of delayed closing.
- (5) Frequency: the working frequency of the high-voltage circuit inside the nozzle.
- (6) Upper limit of power: set the upper limit of plasma power alarm. If the actual power exceeds this value and the power monitoring function is turned on, the system will prompt that the power is abnormal and stop working.
- (7) Lower limit of power: set the lower limit of plasma power alarm. If the actual power is lower than this value and the power monitoring function is turned on, the system will prompt that the power is abnormal and stop working.
- (7) Hysteresis time: the reaction time of system alarm delay when the actual power of the nozzle is not within the upper and lower limits of the set power alarm.
- (8) Power monitoring: whether to turn on the power monitoring function, "NO" means on; "OFF" means off. If the machine is not equipped with accessories for power monitoring, turning on this function system will give an alarm and stop working.

- (9) Ignition duty ratio: the duty ratio used when the plasma is just started. Modifying this value directly affects the starting current, and the larger the value, the greater the current.
- (10) Preset duty ratio: the duty ratio used in plasma operation. Modifying this value directly affects the plasma power, and the larger the value, the greater the power.

## VIII. Description of remote communication interface

### 8.1 Description of Remote Interface Wiring

- (1) Red: Remote RS485 signal A (it will be effective only after the remote RS485 is enabled by short circuit of yellow and green, and the touch screen function is replaced by an external controller).
- (2) Red and black: remote RS485 signal B (it will be effective only after the remote RS485 is enabled in yellow and green, and the touch screen function is replaced by an external controller).
- (3) Black: RS485 signal A of the external power metering module (touch screen or external controller (through red and red and black) reads the power of the metering module connected here and writes it into the plasma control panel for power monitoring).
- (4) Black and white: RS485 signal B of external power metering module (touch screen or external controller (through red and red and black) reads the power of metering module connected here and writes it into plasma control panel for power monitoring).
- (5) Yellow: the negative pole of 0V and 24V switching power supply.
- (6) Yellow-black: short circuit with yellow will start the plasma.
- (7) Green: Remote RS485 enabled.
- (8) Green-black: short circuit with yellow and then release to reset the plasma alarm.
- (9) White, white and black: passive output of plasma alarm, and both of them are returned during alarm.
- (10) Brown and brown-black: passive output during plasma operation, and both are turned on when plasma occurs.
- (11) Blue and blue-black: the passive output of the plasma system to the control signal of the external electromagnetic valve, which can be used to control the plasma nozzle to inject air, with its own turn-off delay.
- (12) Purple, purple-black: the passive output of the plasma system to the control signal of the external exhaust device, which can be externally connected with the exhaust device and has its own turn-off delay.
- (13) Gray, gray-black: the passive output of the plasma system to the control signal of the external electromagnetic valve can control the external cooling gas of the plasma nozzle by an external electromagnetic valve, which is turned off when the plasma is started and cooled when the plasma is turned off.

### 8.2 Description of Remote Interface Communication

485 Communication protocol:				
9600, 8, N, 1				
Modbus RTU, The address code is 5, Only 03, 06, 01 and 05 function codes are supported.				
Register definition:				
Address (DEC)	Content (16 bits)	Read and write	Corresponding function code	Instructions for use:

2	Power monitoring switch	Readable	03/06	=1 Power monitoring is enabled, and abnormal power alarm will be given if the power exceeds the range; =0 Power monitoring is disabled and no alarm will be given.
3	Speed monitoring switch	Readable	03/06	=1 Enable speed monitoring; if the speed exceeds the range, an abnormal speed alarm will be given; =0 disables speed monitoring and will not give an alarm.
4	Selection of rotary/direct injection	Readable	03/06	=1 rotary spray; =0 direct injection
6	Signal number of one revolution	Readable	03/06	
7	Plasma frequency	Readable	03/06	30,40, to turn off the plasma to turn on the new setting value is effective.
10	Upper limit of speed	Readable	03/06	Range of speed monitoring
11	Lower speed limit	Readable	03/06	
12	Preset power regulation	Readable	03/06	The recommended range is 50~300, and the new setting value will be effective only if the plasma is turned off and turned on again.
13	Speed hysteresis time (s)	Readable	03/06	It is not effective until the speed is out of range or back in range.
19	Upper power limit	Readable	03/06	Scope of power monitoring
20	Lower power limit	Readable	03/06	
21	Ignition power regulation	Readable	03/06	Plasma starting power, the recommended range is 50~300, and the new setting value is effective only when the plasma is turned off and turned on again.
22	Power hysteresis time (s)	Readable	03/06	Power out of range or back in range will not be effective until this time.
32	version number	read only	03	
39	Current speed (r/min)	read only	03	
82	Current power (0.1W)	Readable	03/06	The power read by the screen or the upper controller from the electric energy meter is sent here, and the control panel judges whether the power is abnormal.

Bit definition:

Address(DEC)	Content (16 bits)	Read and write	Corresponding function code	Instructions for use:
0	Power abnormal state	read only	01	=1 normal, =0 abnormal.
1	Rotating nozzle	Readable	01/05	
2	Start pumping	Readable	01/05	Closing delay is about 1min.
3	Starting cooling gas	Readable	01/05	Automatically shut down in the plasma start-up state, and start and stop with the gas jet in the plasma shut-down state.
4	jet air	Readable	01/05	Closing delay is about 10min.
5	reserve			

6	Communication plasma reset	Readable	01/05	Serial port clearance plasma alarm. After all anomalies disappear, the alarm can only be cleared by clearing the signal.
7	Communication plasma start	Readable	01/05	When the serial port starts plasma, it will start jet, suction and rotation at the same time; Turn off only the plasma when turning off.
8	Plasma start input IO state	read only	01	=1 has input, =0 has no input. Will start jet, suction and rotation at the same time.
9	Air pressure sensor input IO status	read only	01	=1 input, =0 no input.
10	Plasma reset input IO state	read only	01	=1 input, =0 no input.
11	Plasma startup failure state	read only	01	=1 failed, =0 succeeded.
12	NTC bypass input IO status	read only	01	=1 input, =0 no input.
13	Abnormal speed state	read only	01	=1 normal, =0 abnormal.
14	Plasma alarm state	read only	01	=1 alarm, =0 no alarm.
15	Plasma working state	read only	01	=1 working, =0 not working.
16	Heat sink temperature alarm status	read only	01	=1 alarm, =0 no alarm.
17	Transformer temperature alarm state	read only	01	=1 alarm, =0 no alarm.
18	Temperature sensor 3 alarm status	read only	01	=1 alarm, =0 no alarm.
19	Air pressure alarm state	read only	01	=1 alarm, =0 no alarm.
20	NTC bypass alarm status	read only	01	=1 alarm, =0 no alarm.
21	Plasma current sensing input IO state	read only	01	=1 input, =0 no input.
22	Heat sink temperature input IO status	read only	01	=1 input, =0 no input.
23	Transformer temperature input IO state	read only	01	=1 input, =0 no input.
24	Temperature sensor 3 inputs IO status.	read only	01	=1 input, =0 no input.
25	Rotating overcurrent input IO state	read only	01	=1 input, =0 no input.
26	Rotating overcurrent alarm state reserve	read only	01	=1 alarm, =0 no alarm.
27				

28	reserve			
29	reserve			
30	reserve			
31	reserve			

## IX. Nozzle maintenance

Steps of cleaning the Plasma electrode: remove the Plasma electrode, wipe off the black substance on the electrode with polishing paper, clean the electrode surface with a dust-free cloth, and finally install and reset the plasma electrode. The specific steps are as follows:

- (1) Remove the outer layer protection of the nozzle and the nozzle clockwise, as shown in Figure 7-1;
- (2) Remove the outer protection of the Plasma electrode clockwise, as shown in Figure 7-2;

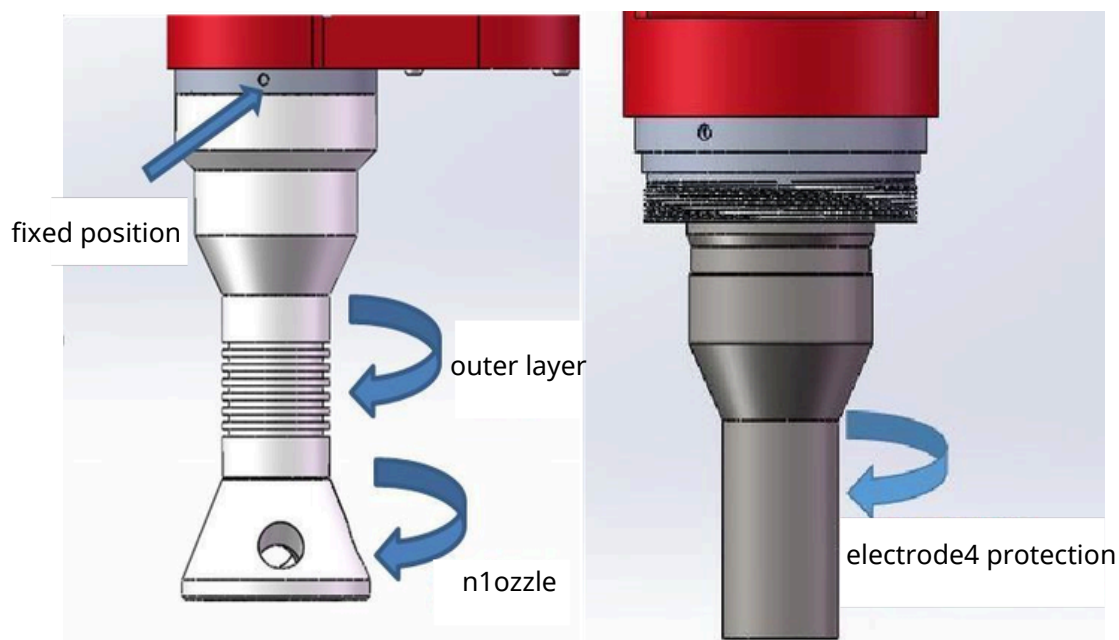

Figure 7-1 Outer layer protection of nozzle and Figure 7-2 Outer layer protection of plasma electrode

- (3) Remove the Plasma electrode insulation protective sleeve (high-voltage isolation tube), as shown in Figure 7-3;
- (4) Remove the Plasma electrode clockwise, as shown in Figure 7-4;

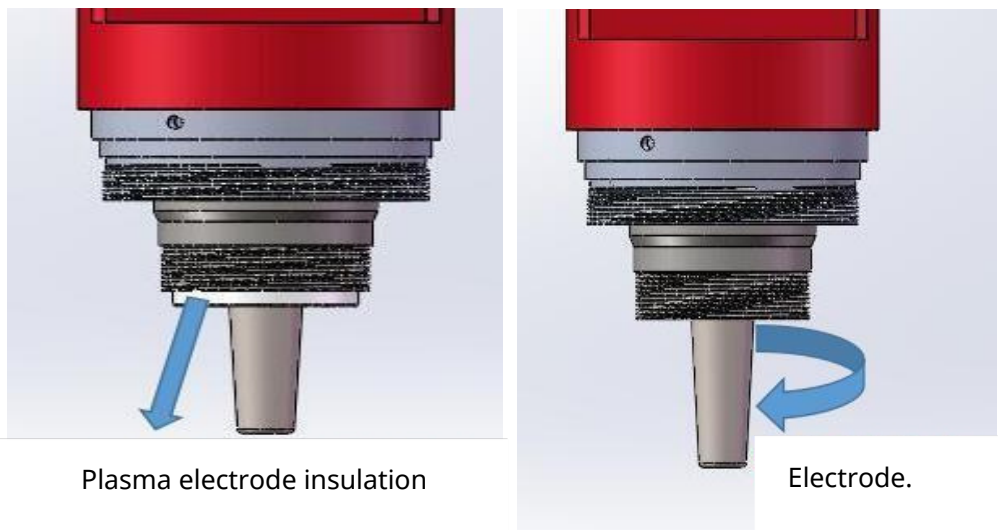

Figure 7-3 Plasma electrode insulation protective sleeve Figure 7-4 Plasma electrode  
After it is removed, it is shown in Figure 7-5 below, in which 5 is the electrode. Take out the electrode, and use polishing paper to remove the black substance on the surface.



Figure 7-5 Disassembly of Plasma Electrode Figure 7-6 Plasma Electrode

## X. Prevention and elimination of common faults

Fault phenomenon		failure cause	debugging
Host part	Barometer alarm	Air pressure exceeds the set value	<ol style="list-style-type: none"> <li>1. Check whether the input air pressure is normal;</li> <li>2. Whether the pneumatic pipeline is bent and the switch is turned on;</li> <li>3. Adjust the barometer to the set value.</li> </ol>
	Nozzle does not rotate	Wear of belt, bearing and motor	<ol style="list-style-type: none"> <li>1. Check whether the belt is damaged;</li> <li>2. Turn the plasma nozzle manually to see if there is abnormal sound.</li> </ol>
Spray gun part	Plasma-free		<ol style="list-style-type: none"> <li>1. Check whether the grounding wire is loose;</li> </ol>

	ejection		<ol style="list-style-type: none"><li>2. Whether the host switch is on;</li><li>3. Check whether the high-voltage isolation tube is broken down.</li></ol>
--	----------	--	--

**Note: It is forbidden to dismantle and replace equipment components without permission. Please contact us if you need service!**