

VC-450M Series Inline Plasma Cleaner User Manual



JIT IndustrialAsia Pte Ltd

URL: [wwwhttp://jit-asia.com.sg](http://jit-asia.com.sg)

Preface

The company enjoys and reserves the exclusive rights of all works in accordance with the copyright law. Without the permission of the company, it is not allowed to increase, decrease, adapt or reproduce this manual in any form.

Model : VC-450M Inline Plasma Machine Serial :

Software: _____

Date of Production: _____

The VC-450M series and logo are owned by VECTRON. This manual is subject to modification or update without notice.

I.VC-450M Function

VC-450M is a machine that applies high temperature and high pressure to the air in an environment that does not require vacuum to generate ionized plasma. The total number of electrons of cations and anions in the plasma is almost equal, and the plasma

is in a neutral state. The ions and electrons in the plasma collide with the surface of the substrate at high speed, remove foreign matter attached to the surface of the substrate, and attach functional groups to the surface. This process can clean the surface and obtain the effect of hydrophilization. At the same time, the functional groups attached to the surface of the substrate increase the surface energy of the substrate, thereby enhancing the surface adhesion of the substrate. Function:

1. Eliminate static electricity on the surface of the substrate, clean and activate the surface of the substrate, improve the surface energy of the substrate, and improve the adhesion between the adhesive and the substrate ;
- 2.Low plasma temperature, no damage to the substrate ;
- 3.No arcing, no damage to the chips of the processed products ;

Application

1. Electronic and electrical industry (printed circuit board bonding, wafer/chip/LED, mobile phone glass cover & middle frame, etc.) ;
2. Packaging and printing industry (plastic packaging, toy products, paper & carton

printing, cosmetic packaging, etc.) ;

3. Automotive industry (lights, EPDM weather strips, interior and exterior automotive trims, instrument panels, automotive electronics, etc.) ;

4. Textile industry (outdoor clothing surface printing, fabric & non-woven fabric dyeing, shoe material gluing, etc.) ;

II. Warranty and Service Range

This equipment has been debugged and checked OK before leaving the factory. The company will guarantee it when it is used within the following conditions.

1. Warranty Period

One year after the device leaves the factory.

2. Service area

The company will repair the faults during normal use during the warranty period free of charge, but will not be covered by the warranty in the following cases.

Use consumables and components not specified by VECTRON.

Improper use by the operator, or improper maintenance.

Normal loss of consumables.

Other natural disasters.

The color of the device shell fades naturally.

The heat and noise change without affecting the normal operation of the

equipment.

Noted: If you encounter problems that you do not understand in the actual process, please check the manual, or contact our company.

3. Free range of services

This device will provide free service for the following situations after leaving the factory.

Assembly debugging and trial operation.

Processing program making or education training and related technical guidance.

Operation, circuit analysis and other related education training.

III. Specification

No.	Item	Specification	Noted
	Model	VC-450M	Appearance white

1	Device Platform Section	Size(mm)	800*1270*1450 (W*D*H)	Excludes footings and lighthouses
2		PCB Size(mm)	50*50~450*400 (X*Y)	
3		The distance from the front edge of the equipment to the fixed track	About 320mm	
4		Overboard track height (mm)	900+/-20	
5		Overboard height(max)	40mm	
6		Board direction	Lift→Right	Adjustable RL
7		Processing speed range (mm/s)	10~300	
8		Z-axis height control	software control	
9		Z-axis height adjustment range (mm)	0~80	
10		Abnormal alarm	Air pressure, power, temperature and other abnormal alarms	Digital air pressure
11		Control System	Industrial control + servo control	
12		Track load	10kg	
13		Delivery system	Track transfer (automatic width adjustment)	one-piece chain
14		Stop system	Cylinder	
15		Operating system	Win10	
16		Equipment operating software		
17		Vacuuming and deodorizing system	Forced negative pressure exhaust + dust box	
18	Equipment	Power Supply	AC220V 50/60Hz	

19	electrical part	External air source(MPa)	CDA 0.4~0.8	
20		Total power (KW)	2.5	
21	Plasma System Section	Plasma System Type	Single head, rotary spray	import system
22		Plasma System Power(W)	600~800 (Max)	
23		High voltage discharge voltage (KV)	8~12	
24		Working discharge frequencyKHz	40	
25		Gas flow (L/Min)	40	
26		optimal handling height (mm)	12~16	
27		Nozzle model	Ø20mm/ 90	Optional Ø40, Ø60

Note:Theabove parameters are standard configuration. If there are special needs, theycanbecustomized according to customer requirements. If the technical parametersarechanged without prior notice, the final interpretation right belongs to "VECTRON".

IV.Installation

1.Environment setting

1.1 This equipment should be installed in a ventilated and dry place, and do not install it in a corrosive and flammable place.

1.2 This equipment should be installed in a place with no sunlight exposure and high heat.

1.3 This equipment should be installed in a place free from vibration, easy maintenance and inspection.

1.4 This equipment should be installed in a place with less dust, oil and gas and metal dust.

1.5 This equipment should be installed in a place free from electromagnetic noise interference.

2.Equipment installation

2.1 Place the device in the specified position.

2.2 Adjust the level of the equipment with a level and tighten the screw of the foot cup.

2.3 Connect the air connection tube to the air connection port of the device.

2.4 Connect the power plug to the device.

2.5 Grounding requirements: Please connect this device to the ground wire of the distribution box separately, and do not connect it in series with other devices.

2.6 Confirm that the upper and lower signal lines are connected properly and can communicate normally.

3. Power supply, electrical configuration

3.1 The standard input of this equipment is single-phase 220V AC 50/60Hz, 2.5KW.

3.2 The standard air pressure of this equipment is 0.4-0.6 MPa.

3.3 This equipment has high-voltage circuit devices, please do not touch devices with high-voltage signs.

Note: The ground wire of the power grid meets the international requirements of the Equipment room, and ensures that the equipment shell is well grounded.

V. Appearance Size

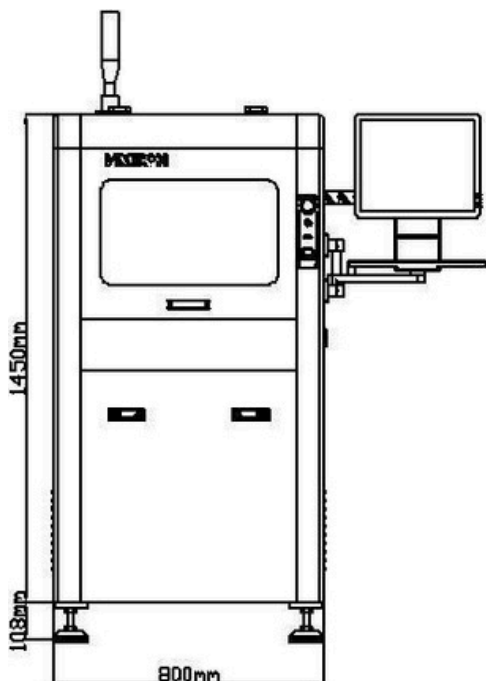

Front view

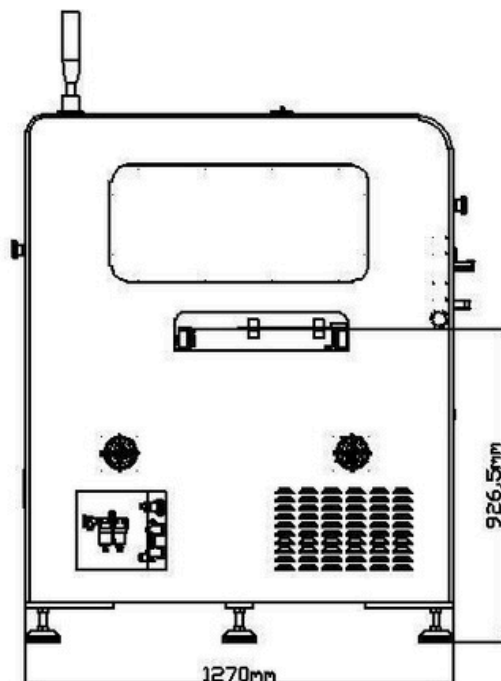

Side view

Chapter 1: Machine Description

I. Machine Appearance Description



1.1 Lighthouse

Red: Illuminates when the equipment is not ready, the emergency stop button is pressed, the safety door is opened, or there is a fault.

Yellow: The device is normal and lights up when it is in the state of waiting for production.

Green: This light is on when the device is operating normally.

1.2 Monitor

Display program interface buttons and processing status

1.3 E-stop button

Whenever the button is pressed, the device stops functioning. The switch is a self-locking switch, if you want to remove it, please turn it clockwise.

1.4 Main Power Switch

Turn all power to the device on and off.

1.5 Digital Pressure Gauge

Used to monitor the air pressure to meet the equipment requirements

1.6 USB Port

Used for connection and communication between industrial computer and external devices.

1.7 Convey Track

Used for PCB board to enter the equipment for surface treatment.

1.8 Electronic port

Used to connect external power and air sources to the device.

1.9 Cooling Fan

After the main power switch is turned on, the cooling fan will run automatically, mainly to dissipate heat for the internal circuits of the device, the host and other components.

II. Keyboard Button Operation Instructions

Press the keyboard F2 shortcut window (this function will be used frequently); Display as shown below ;

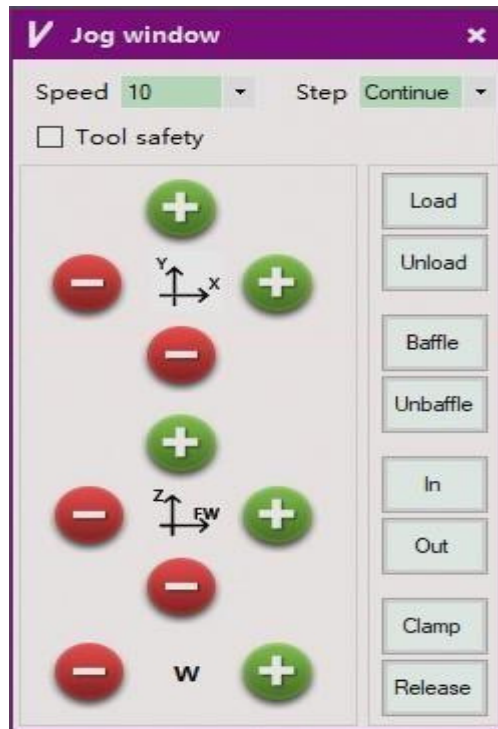

X represents the X axis of the nozzle; Y represents the Y axis; Z represents the Z axis of the nozzle; W represents the PCBA feed track;

① Speed: Select the "10" position, indicating that the current moving speed is 10mm/s, as shown in the figure below ;



② Route: Selecting a certain value indicates how many millimeters the corresponding axis moves when the left mouse button is clicked once; if "Continue" is selected, it will move continuously with the values selected in the speed.

③ Tool Safety (Nozzle security) : If this parameter is selected, it means that after the nozzle moves to the set safe value, it is not allowed to continue to move down ;

④ Loading: Click "Load", the front end of the track senses the PCBA board signal (the track width needs to be adjusted according to the width of the PCBA board), the PCBA board will be moved to the parking position, and then the pressing and clamping actions will be performed. At this point, you can move the lens to the coordinate position to be set by moving the camera up, down, left and right to perform programming actions;

⑤ Unloading: Click "Unload" to perform the action of loosening and lifting the board, and the conveying track will send the parked PCBA board to the exit at the rear end of the track, waiting for the board to be taken out;

⑥ Baffle \ Unbaffle : click "fender" or "release board", step by step to perform the corresponding action;

⑦ In: Click "In", single-step the action of entering the board and transfer the PCBA board rail to the baffle location;

- ⑧ Out: Click " Out", Single-step execution of the board-out action requires the PCBA board to be in the state of placing the board and releasing the board;
- ⑨ Clamp\Release : " Clamp"Or" Release ", Step through the corresponding action ;

III. Boot Operation

- 3.1 Confirm that the equipment is properly connected to the power and air supply ;
- 3.2 Turn on the main power switch of the device (rotate it to the "ON" state) ;
- 3.3 After the equipment is powered on, press the "light source start button" button to light up the lighting system of the equipment; then press the "PC POWER start button" button for about two seconds to power on the industrial control computer of the equipment;
- 3.4 After the equipment industrial control computer is started, double-click the

sub-board computer control software on the display desktop "
A login window will pop up, as shown below :



After entering the login name and login password (the default login name is: 123, and the login password is: 123), click "Login" to enter the main interface of the control system. As shown below :

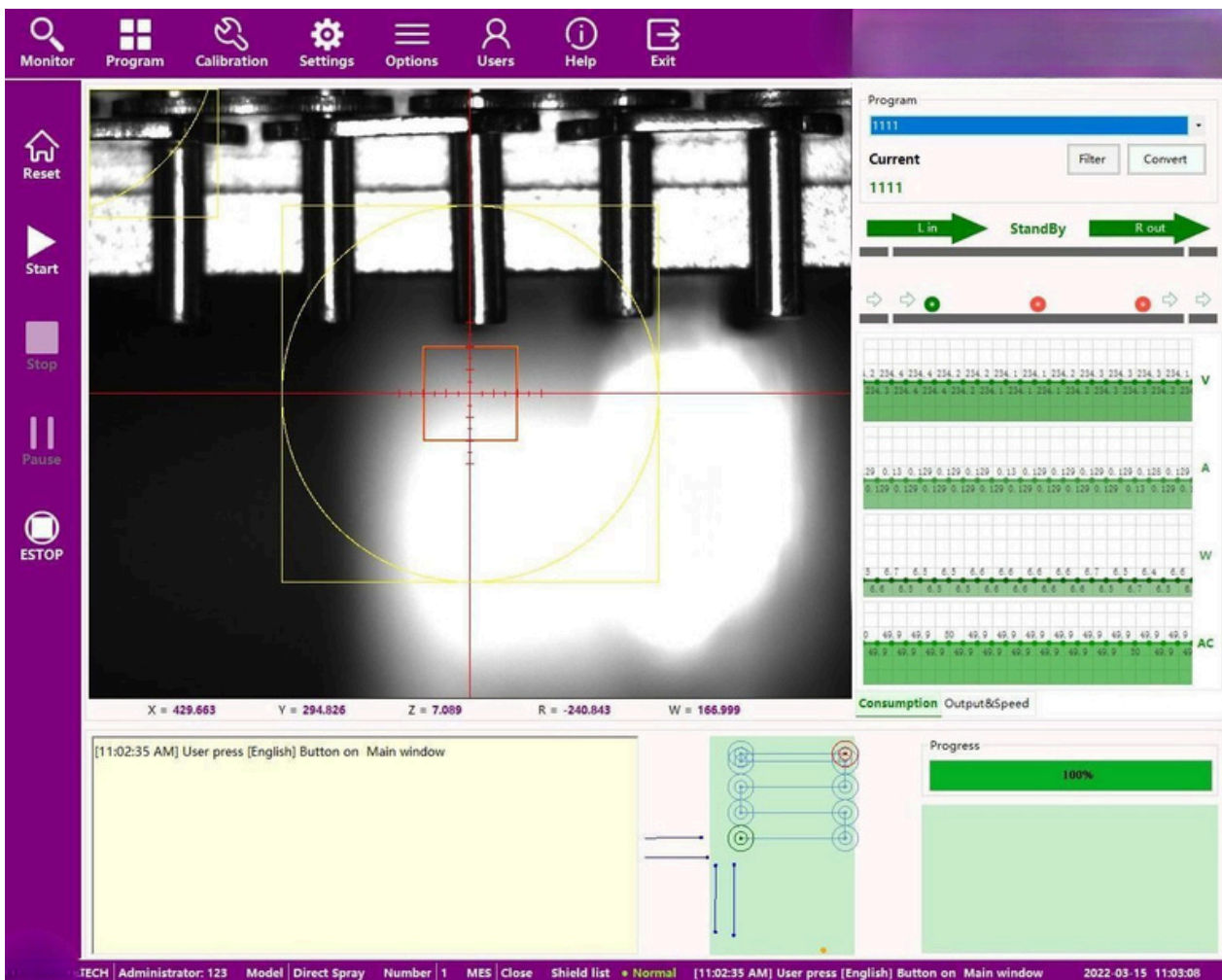

3.5 Click the "Reset" button at the top left of the main interface, and after the device is reset, it can operate normally.

IV Shutdown Operation

- 4.1 Make sure that the equipment is in a shutdown state ;

4.2 Click on the top right of the main interface "  ", Prompt whether to exit the system, click "Yes" to exit the control system ;

4.3 Press the "light source start key" button to turn off the equipment lighting system ;

4.4 Exit the Windows system ;

4.5 After the above steps are completed, turn off the main power switch of the device (rotate it to the "OFF" state), and the shutdown operation is completed at this time.

Chapter 2: Control Software Description

I. Software Interface Function Description

After the industrial control computer is successfully started, open the control software, enter the user name and password, and after the "reset" action is completed, it will display as shown in the figure below ;

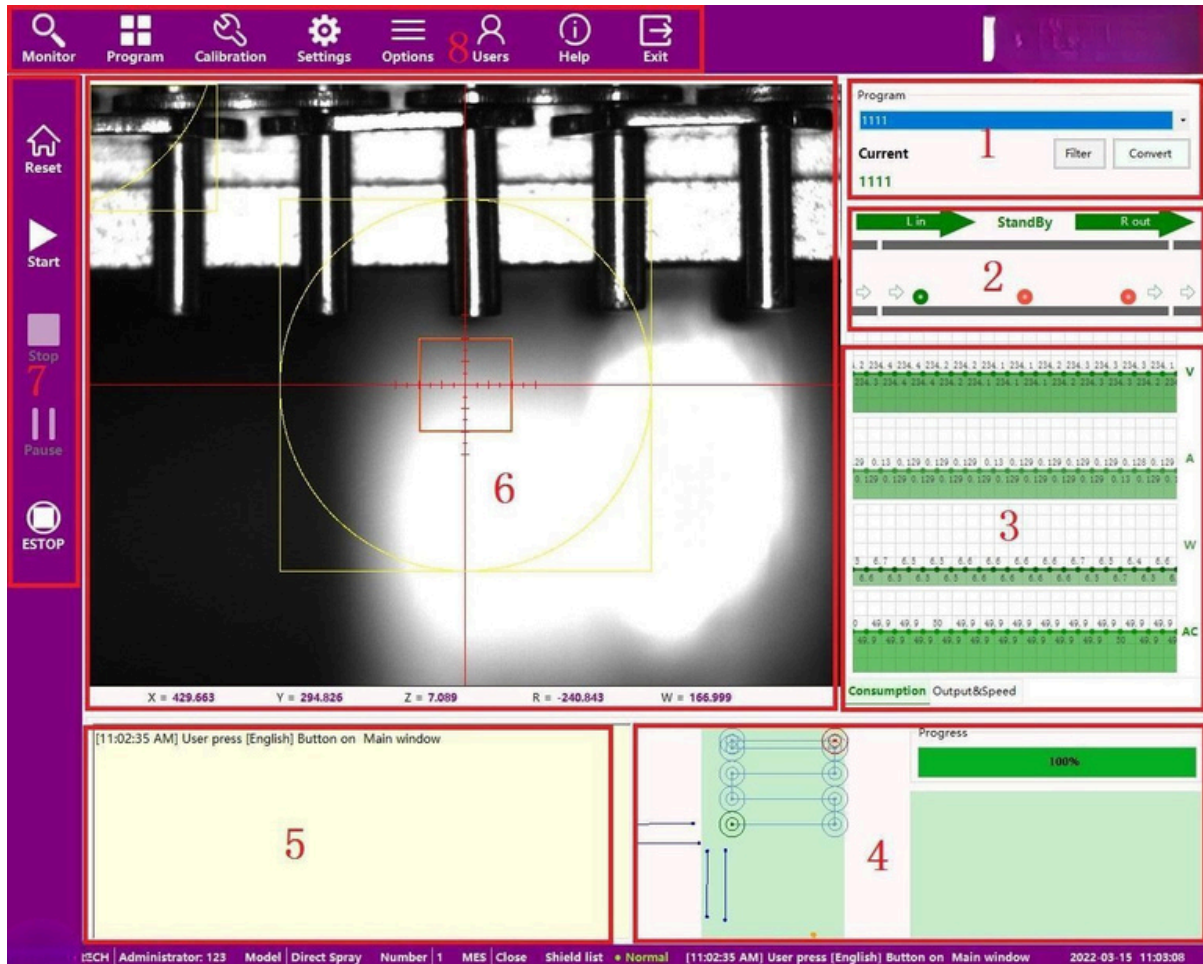

1. Program Management

Program Name: Display the name of the current production scheme and related information; if you need to change the scheme, click the drop-down menu on the right to select the scheme to be produced, and click "Convert Now" to complete the conversion of the scheme; 2. Machine State: Display the current state of the device ; 3. Plasma power consumption/yield & speed

Plasma power consumption is displayed as shown below :



V: Displays the real-time voltage of the current device;

C: Display the real-time current of the current device;

W: Display the power of the real-time nozzle of the current equipment;

AC: Displays the real-time power frequency of the current device ;

The output & speed are displayed as shown below :

Work time - Output			
Single time(s)	<input type="text" value="0"/>	Pro Output(panel)	<input type="text" value="0"/>
Pro Time(h)	<input type="text" value="0"/>	Local output(panel)	<input type="text" value="0"/>
Local time(h)	<input type="text" value="0"/>		
Speed			
X speed(mm/s)	<input type="text" value="0"/>	Y speed(mm/s)	<input type="text" value="0"/>
Z speed(mm/s)	<input type="text" value="0"/>	R speed(deg/s)	<input type="text" value="0"/>
Maintenance			
Plasma life(h)	<input type="text" value="26280.000"/>	Plasma used(h)	<input type="text" value="0.000"/>
Suction life(h)	<input type="text" value="4320.000"/>	Suction used(h)	<input type="text" value="0.000"/>
Consumption		Output&Speed	

Workingtime - output

Time: Display the processing time of the current plan and the total processing time of the equipment;

Output: Display the processing output of the current plan and the total processing output of the equipment ;

Single time: Displays the time required to complete a single PCBA;

Speed: Displays the movement speed of each axis of the device;

Maintenance: Displays the current plasma, vacuum cleaner life and elapsed life of the device ;

4. Work progress : Displays the spraying progress of the current program as a

percentage and as a simulated image ;

5. Log display window : Real-time record of operator's operation process, alarm information and operation data during spraying ;

6. Viewing display window : Displays the current camera position in real time ;

7. Machine operation control:

7.1 Reset: Opening the control software, the reset action must be performed first, otherwise the production and operation cannot be performed, and the system will pop up the window as shown in the figure below;

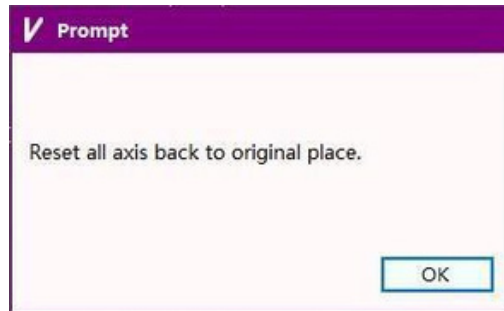

Click the "Reset" button on the upper left of the main interface, after the device reset is completed, the display will be as shown below:



7.2 Start: Select the current plan to be produced, click "Start", and press the start button, the machine starts working

7.2 Stop: When current scheme processing, Click "Stop", machine will finish the whole scheme after stop

7.3 Pause: When current scheme processing, Click "Pause", machine will be pause status immediately, if need go on this scheme, click "continues" start working;

7.4 E-stop: When current scheme processing, Click "E-stop", machine Stop processing immediately; (if need continues work, must be press

" reset" after can back work) .

8. Setting Window

8.1 Processing monitoring: under the monitoring processing state, the operation of each component of the equipment can be monitored;

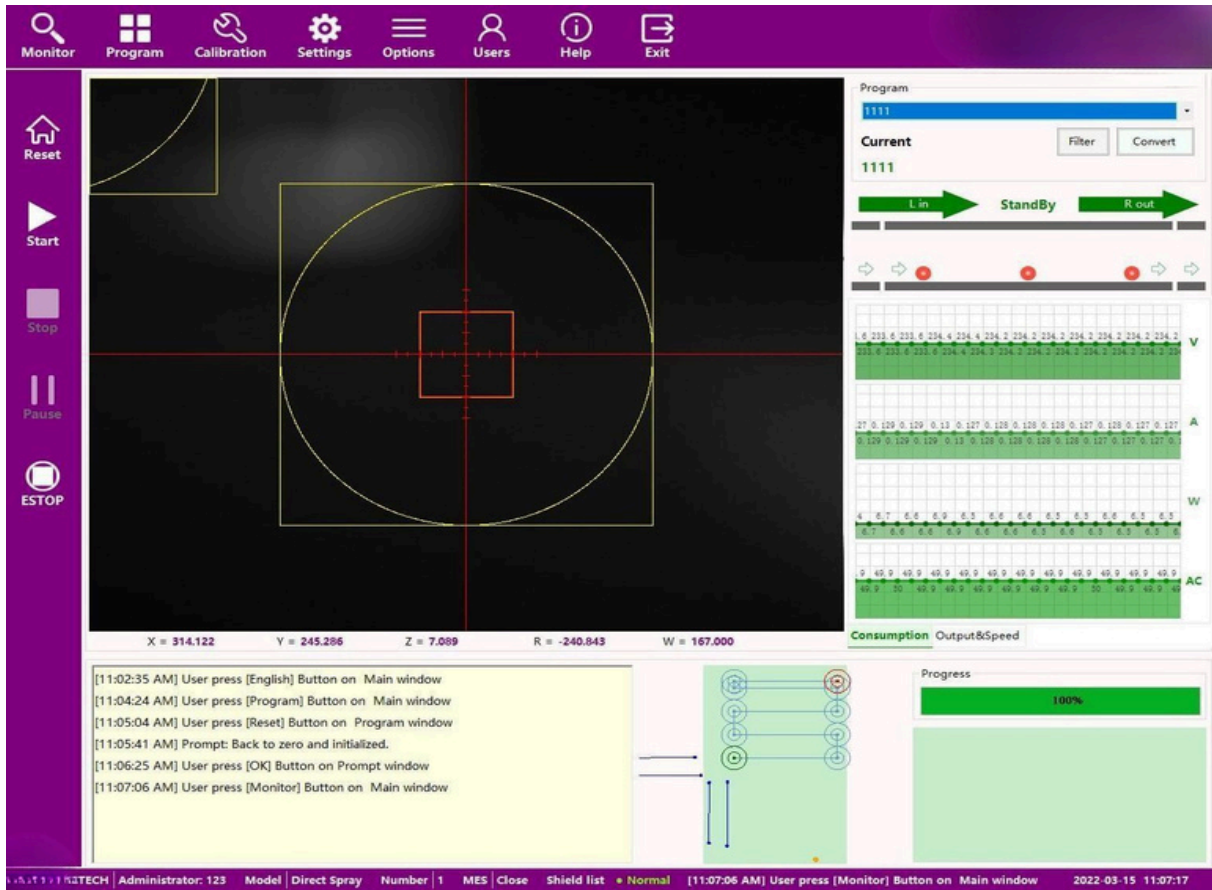

8.2 Program : Click on "Program Settings" to display as shown in the figure below; this part of the content will be introduced in detail in the following chapters.

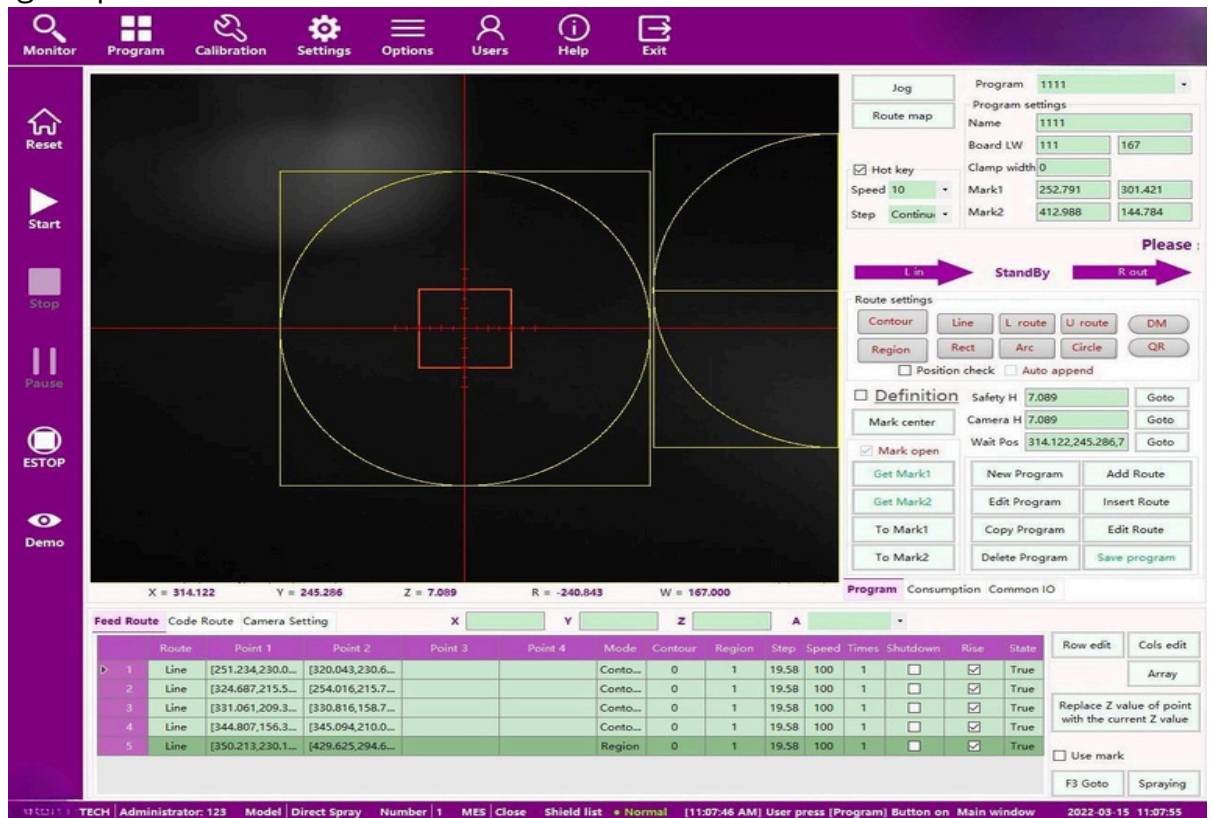

8.3 Calibration: Click "Calibration Settings" to display as shown in the figure below; this part will be described in detail in the following chapters.



8.4 Options: Click "Options" to display as shown in the figure below, "Machine type", "Conveyor", "Front end board out", "Rear end board in", "Yield management"

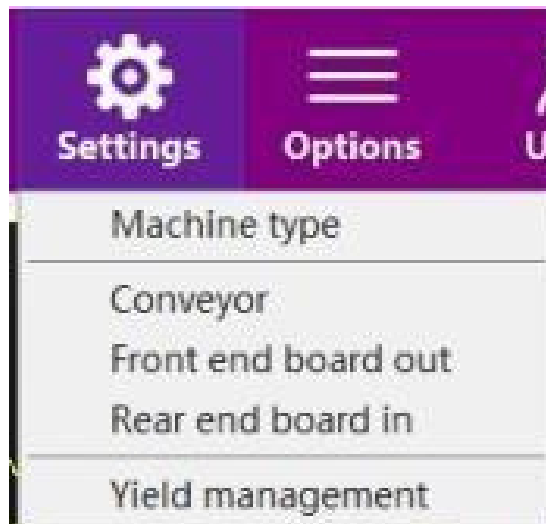

1) Click "Machine type", The "Machine type" pops up, as shown in the figure below;

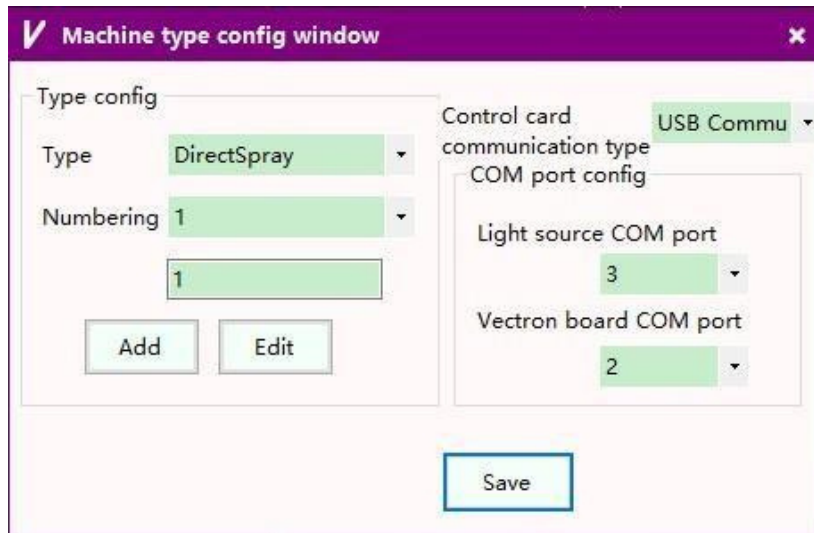

Type: Type optional, include "DirectSpray" n "ObliqueSpray";

Number: According to different types of processing methods, add or modify the corresponding number to facilitate production management;

COM Port Config: Machine combine with other machine has been set before leave factory don't need modify; Conveyor mode: If the device does not need to spray the PCBA, it is only used as the function of transmitting the PCBA, check "The machine only passes the board";

2) Click "Conveyor Mode", transfer PCBA only;

3) Click "Front end board out", machine is left in board and left out board ;

4) Click "Rear end board in", The device is the right input and the right output board; if both are selected at the same time, the right input and the left output board are used.

5) Click "Yield Management", pop up "Count Settings Window", as shown in the figure below;

3) Click "Advance", pop up "Advanced window", as shown in the figure below ;

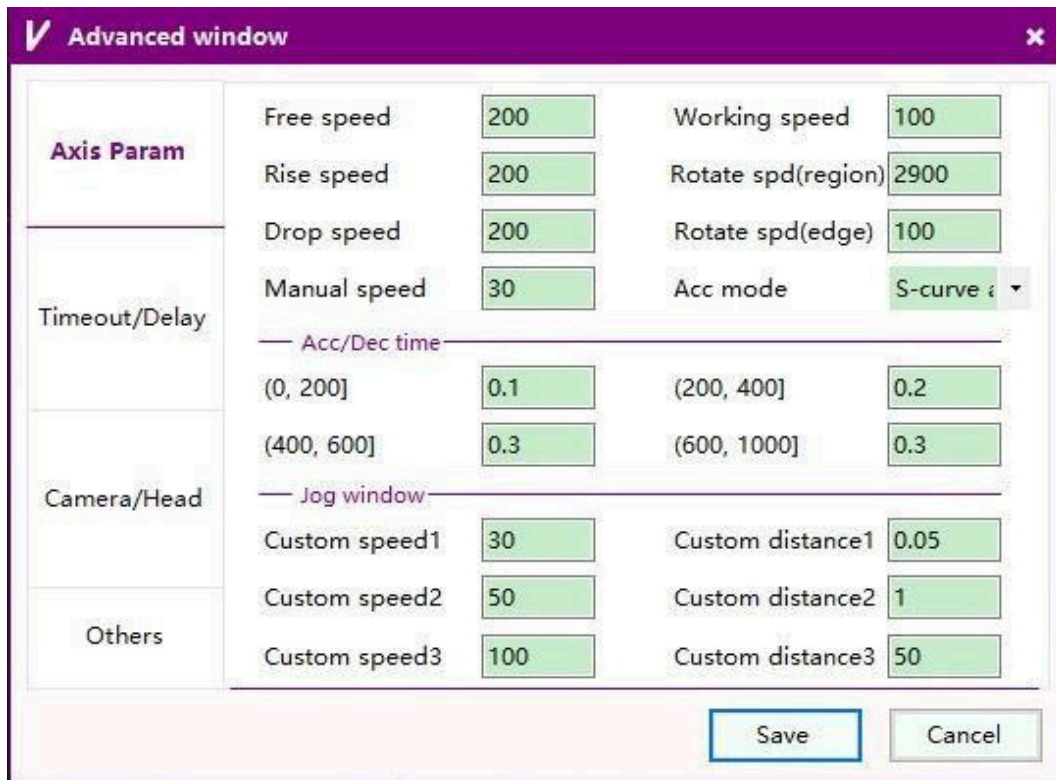

AxisParam:

Free speed : Under working or Demo mode the speed of non-work movement , mm/s;
Rise speed: Under working or Demo mode the rise speed of Z axis mm/s;
Drop speed: Under working or Demo mode the drop speed of Z axis mm/s ;

Manual speed: Click camera image window the speed of camera

movement mm/s;

Working Speed (path): under working mode the work path movement speed mm/s;

Rotate Speed (region): The rotation speed of the R axis when spraying in the area, the unit is mm/s; the rotation speed (contour): the rotation speed of the R axis when the previous edge transitions to the next edge when the contour spraying, the unit is mm/s;

Acc Mode: When the servo accelerates, the mode has been set at the factory, please do not change it! Acceleration and deceleration time: The mode has been set at the factory, please do not change it!

Custom speed: According to your needs, set the selectable moving speed in the shortcut window,mm/s;

Custom step distance: In the setting shortcut window, the selectable single moving distance;

Timeout/Delay:

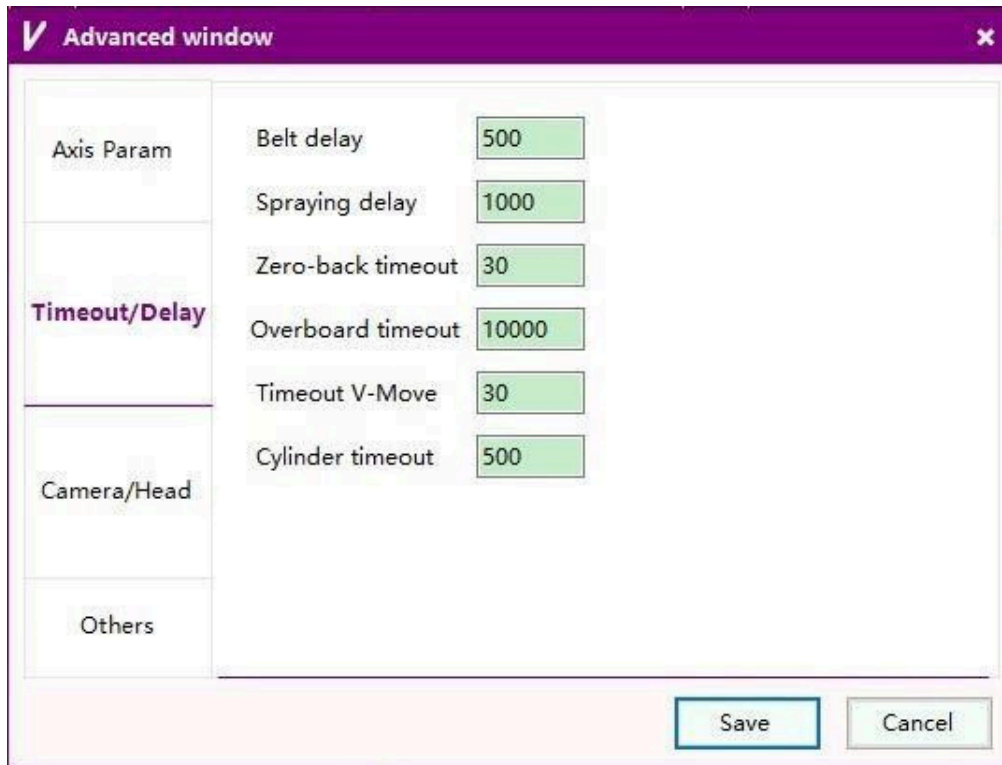

Beltdelay : When it is sensed that the PCBA is transferred to the spraying position, the time that the belt continues to run to ensure that the PCBA board is transferred in place, ms;

Spraying delay: The time to spray after the corresponding time after the plasma is turned on, ms;

Zero-back timeout: If the device fails to return to zero within the set time, the system will alarm, s;

Timeout V-Move : If the motion axis controlled by the industrial control board does not reach the motion point within the set time, the system will alarm over time, s;

Overboard timeout: If the front track entry and exit board has not reached the designated position after the corresponding time, the system will alarm, ms;

Cylinder timeout: If the action of each cylinder cannot be completed within the set time, the system will alarm, ms;

Camera/Head:

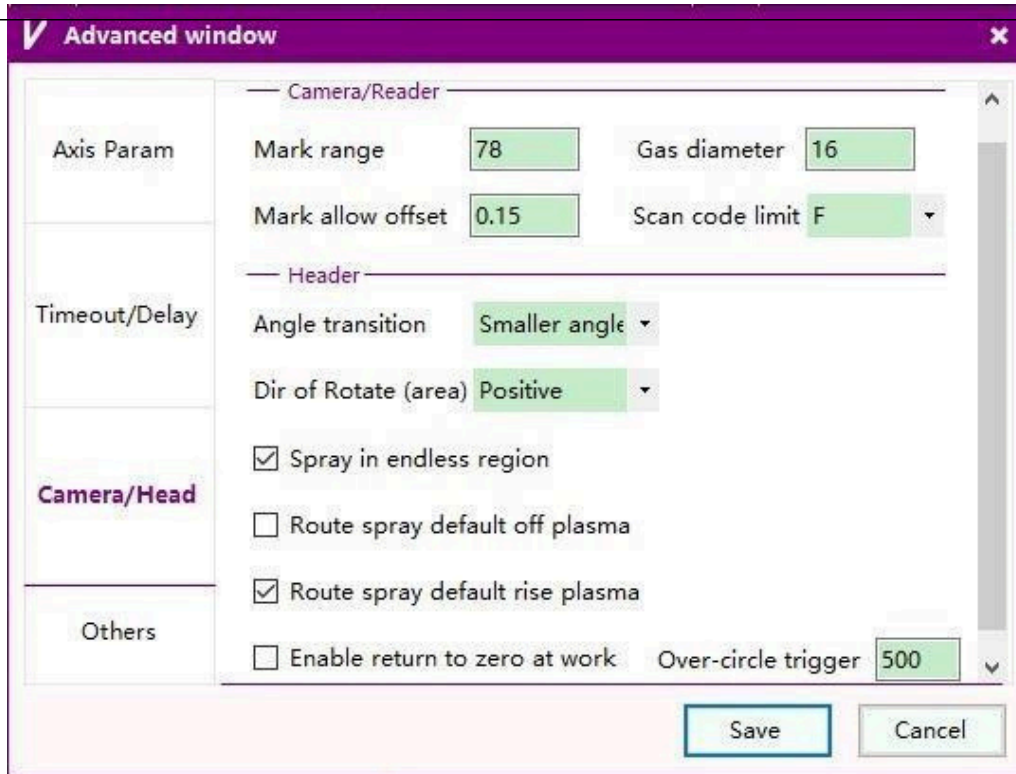

Markrange: Whensettingthemakemark, the effectiveareaofdis crimination; (Note:Theunitisinpixels) !

Markallowoffset: Setthetolerance range allowedbymark, mm;

Gasdiameter: Enterthecorresponding diameteraccordingtothedi ameter ofthecurrentlyinstallednozzle

Scancode limit: Whenusingthecamera codereadingfunction,the system willalarmwhenthereadingcodelevelis lowerthanthesetvalue;

Spray in endless region: When clicked, Spray in endless region, otherwise no spray ;

Route spray default off plasma: When clicked, theplasma is tur ned off afterspraying;

Route spray default rise plasma: When clicked, after spraying, rise nozzle;

Enable return to zero at work: When clicked, Thesprayhead rotatesmorethanthetriggercircleandreturns tozero;

Other

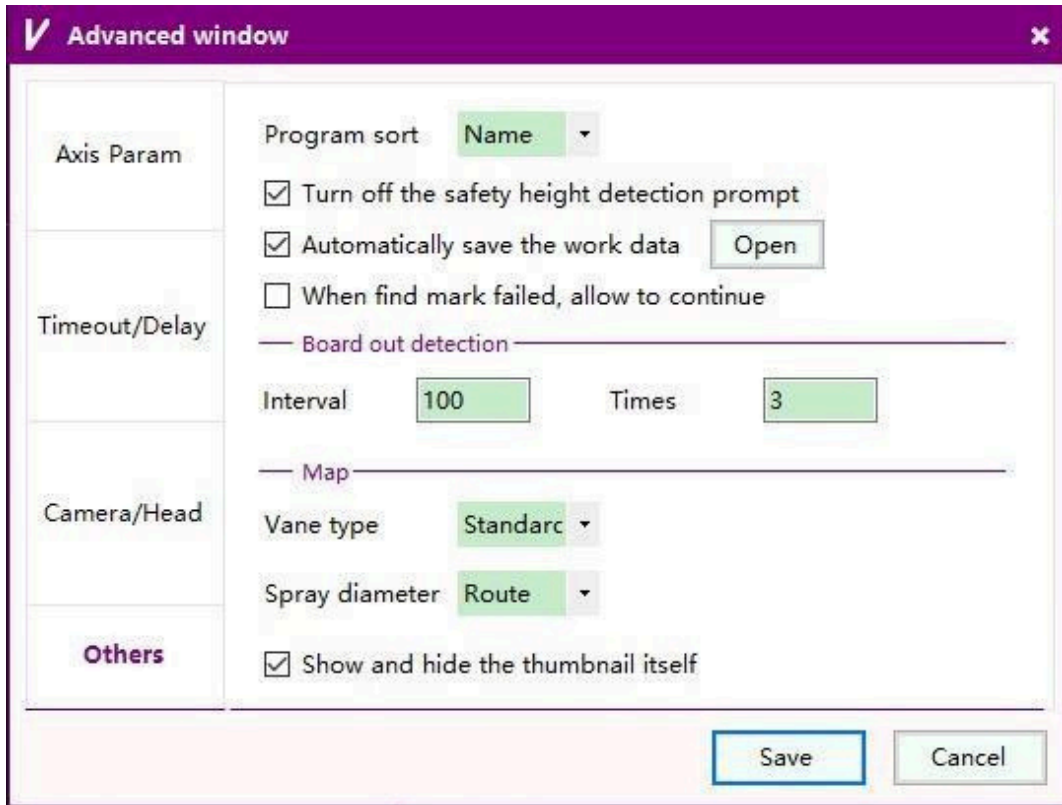

Program sort: Provide "creation time" and "program name", and choose according to the actual situation;

Turn off the safety height detection prompt: When clicked, turn off the security prompt ;

Automatically save the work data : When clicked, machine to record production

Board out detection: The mode has been set at the factory, please do not change it!

Thumbnail:

Vane type include " Simple"、 " standard", shown as below :

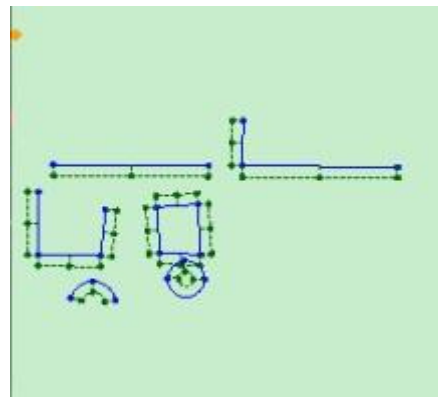
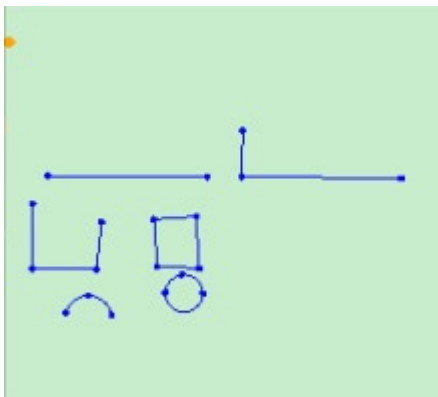

(Simple)

(Standard)

Area circle diameter : Follow system: Use the diameter value of the nozzle of the machine to draw a circle;

Follow path: The layout value set according to the diameter is drawn as the diameter value of the circle;

4) Click " IO test" , as shown in the figure below;

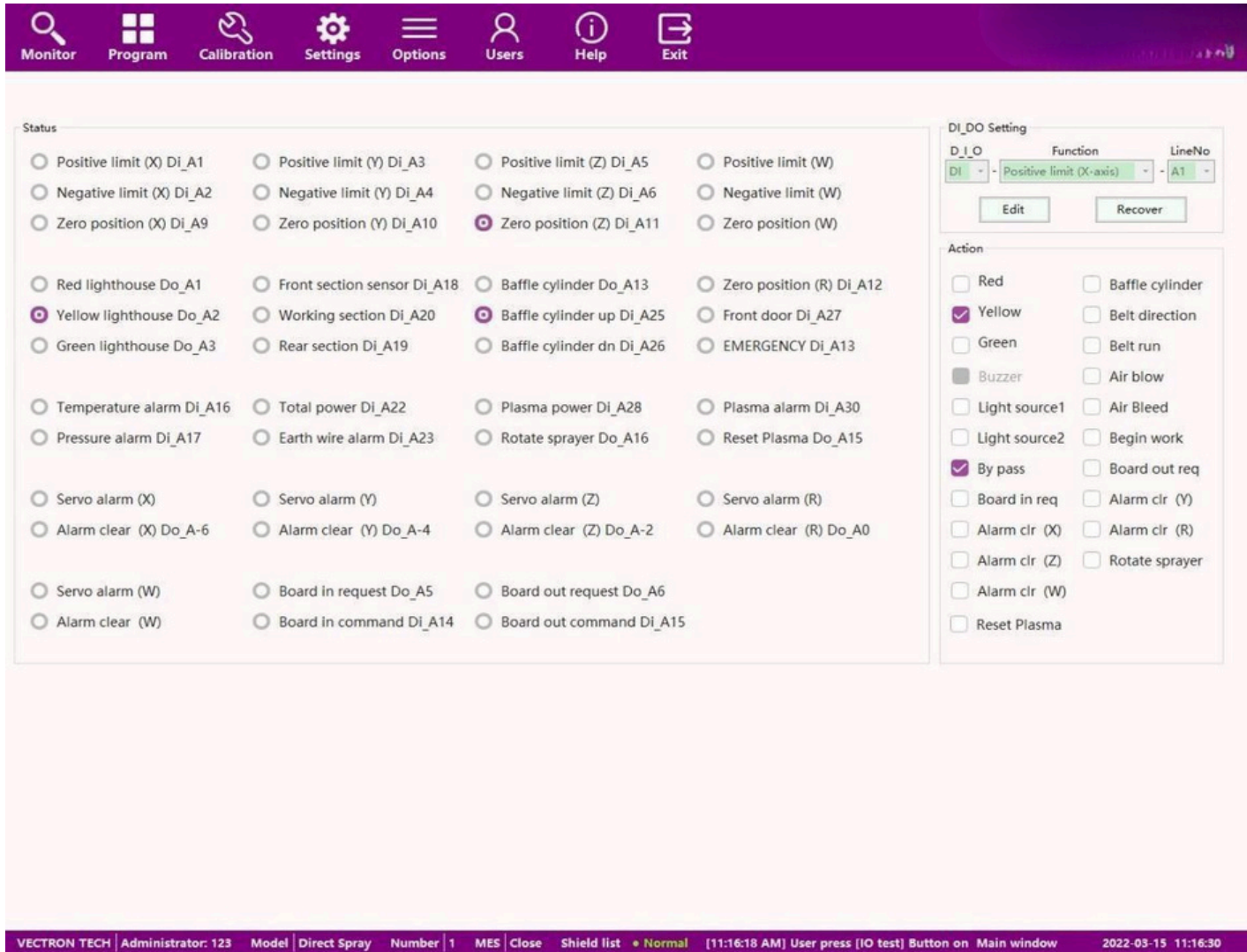

Drive card parameter: This interface displays the status of each axis, limit switch positive, limit switch negative, origin, switch, input IO, output IO and so on.

When the circle is lit, it means this function is valid; if the square is checked, it means that this function is activated ; when the equipment is faulty, it will be used for the convenience of checking the cause of the fault, and will not be explained in detail here.

5) Click "Light source always on", when the checked state is displayed, it means that the camera light source is always on; if it is in the unchecked state, wait for the PCBA to be loaded successfully → find the Mark point successfully → after the code is successfully read, the camera light source does not turn on during the spraying process Bright.

(Note: This function only works during automatic spraying.)

6) Click "Quick Function", and the "Quick Window" will pop up. The content of this part is the same as pressing "F2", and will not be explained in detail here.

10.6 Users Settings: Click "Users Settings", it will display as shown below,



1) Click "Switch user", Pop up "User Login window", display as shown below; press User name and password can enter software;

2) Click "User settings", Pop up "User settings window", as shown below;

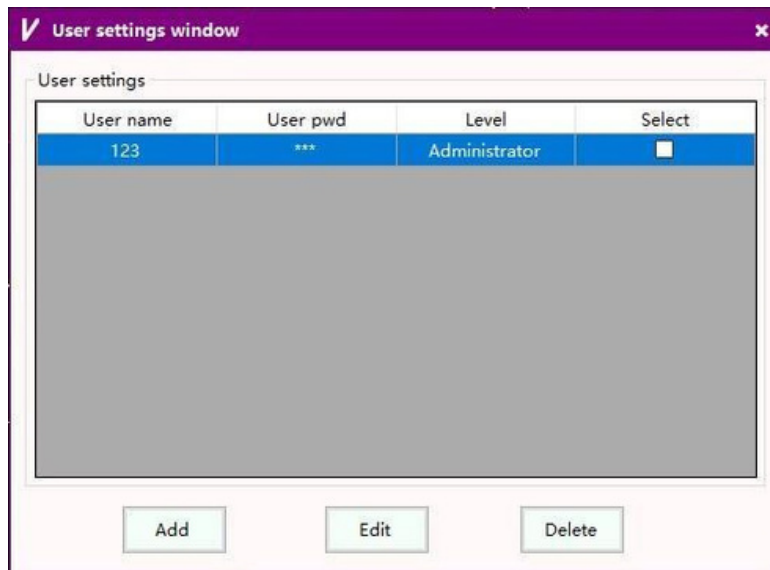

In this window, users with different permissions can be created, which are divided into three types: administrator, engineer, and operator. This function is relatively simple and will not be explained in detail here.

10.7 Help: Click "Help", as shown below;

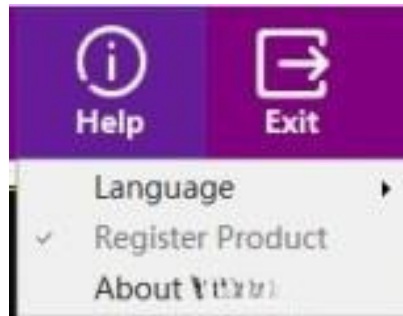

1) "Language" , can be switched to " 中文"或"English";

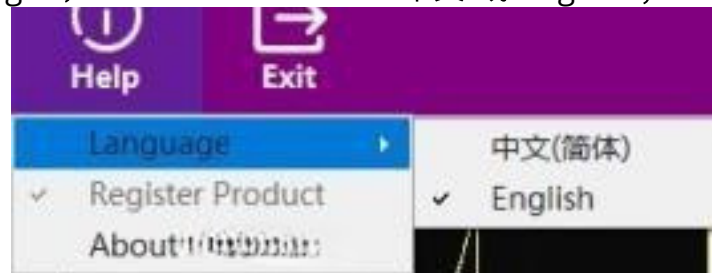

2) "Register Product", this window is only used when registering a product or upgrading a product, and will not be described in detail here.

3) Click " About Vectron" , Pop up window as shown below;



This window is only used when registering a product or upgrading a product.

II. Program Setting

The screenshot displays the SMT program setting software interface. The main workspace shows a coordinate system with a red square and a yellow circle. The right side contains various control panels for Jog, Route map, Program settings (Name, Board LW, Clamp width, Mark1, Mark2), Route settings (Contour, Line, L route, U route, DM, Region, Rect, Arc, Circle, QR), Definition (Safety H, Camera H, Wait Pos), and Mark open (Get Mark1, Get Mark2, To Mark1, To Mark2). A bottom table displays the 'Feed Route' with columns for Route, Point 1, Point 2, Point 3, Point 4, Mode, Contour, Region, Step, Speed, Times, Shutdown, Rise, and State. The status bar at the bottom shows 'iCH | Administrator: 123 | Model | Direct Spray | Number | 1 | MES | Close | Shield list | Normal | [11:07:46 AM] User press [Program] Button on Main window | 2022-03-15 11:07:55'.

Route	Point 1	Point 2	Point 3	Point 4	Mode	Contour	Region	Step	Speed	Times	Shutdown	Rise	State
1	[251.234,230.0...]	[320.043,230.6...]			Conto...	0	1	19.58	100	1	<input type="checkbox"/>	<input checked="" type="checkbox"/>	True
2	[324.687,215.5...]	[254.016,215.7...]			Conto...	0	1	19.58	100	1	<input type="checkbox"/>	<input checked="" type="checkbox"/>	True
3	[331.061,209.3...]	[330.816,158.7...]			Conto...	0	1	19.58	100	1	<input type="checkbox"/>	<input checked="" type="checkbox"/>	True
4	[344.807,156.3...]	[345.094,210.0...]			Conto...	0	1	19.58	100	1	<input type="checkbox"/>	<input checked="" type="checkbox"/>	True
5	[350.213,230.1...]	[429.625,294.6...]			Region	0	1	19.58	100	1	<input type="checkbox"/>	<input checked="" type="checkbox"/>	True

1. NewProgram: Click "NewProgram", then the new scheme can be set up.
2. EditProgram: Click "EditProgram", The content of the currently selected scheme can be modified.
3. CopyProgram: Click "CopyProgram", Re-enter the program name and save to copy the content of the currently selected program.
4. DeleteProgram: Click "DeleteProgram", the currently selected scheme is deleted.
5. AddRoute: Click "AddRoute", You can add a spray route to the last spray route of the currently selected scheme.
6. InsetRoute: Select a certain line of route in the current program and click "InsetRoute" to add a spray route before the selected route.
7. EditRoute: Select the spraying route to be modified in the current program, and click "Edit route" to modify the spraying route.
8. Save program: In the "Add program", "Edit program", and "Copy program" window, click "Save program" to save the content of this program.

The following takes the newly added program as an example to introduce the contents of the program setting interface;

(1) Click "New program", Enter the corresponding content according to the purple prompt font in the figure below;

① In "Program Name", fill in the program name, such as "TEST";

② In the "length and width of incoming board", fill in the length and width of the PCBA, such as "length:200,width:150"; (when filling in the width, add 0.5 to 1mm according to the width of the board);

③ In the "splint width", fill in the width of the splint according to the PCBA situation; In the process of loading, it is found that the clamp is not tight, and then make fine adjustments until the tension of the splint is suitable;

④ Click "Save program", the new program name setting can be completed.



(2) Click "Edit Program", Set other contents of the program;

① Safety Height: According to the thickness of the PCBA board, move the Z-axis of the nozzle, so that the nozzle is 2-3mm higher than the highest component on the board surface, click "Get", this position is the "safe height";
Camera Height: Click "Sharpness", as shown in the figure below, when the value is the largest, the coordinate value of the Z axis at this time is the camera height, click and click "Get", this position is the "Camera Height";

4381.806

Wait Position: move the nozzle to the vicinity of the PCBA to be sprayed, click "Get", this position is the "waiting position";

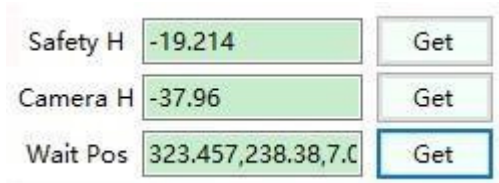

② Click "Enable Mark Points" to set Mark Points;

Definition

1) Move the camera cross cursor to the PCBA board Mark1 point, click "to Mark

Center"

Mark center

The software will automatically find the Mark center, click "Grab Mark1" to complete the Mark1 point setting;

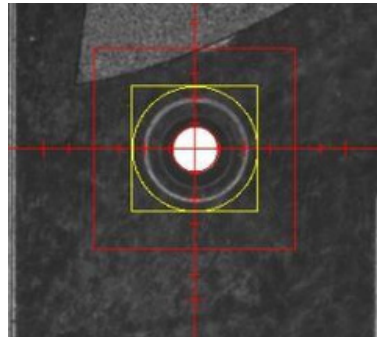
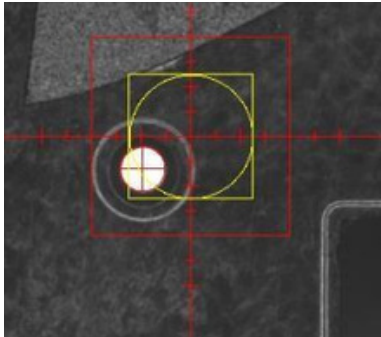

- 2) Click "ToMark1", Verify that the Mark1 position is correct;
- 3) According to the method of setting Mark1 point, set the position of Mark2 point; (if the system cannot automatically find the Mark center, you need to reset the Mark parameters, click "Calibration Settings" to perform "Mark Calibration", this part will be in the "Calibration Settings" chapter details);
 - 4) Click "Save program", to complete.
- 3) Click "AddRoute", include "RouterSetting", "QRcodeRoute setting". Click "Auto Append", After the route is edited, the system automatically appends one to the above route by default; click "route Settings" to display as shown in the figure below;

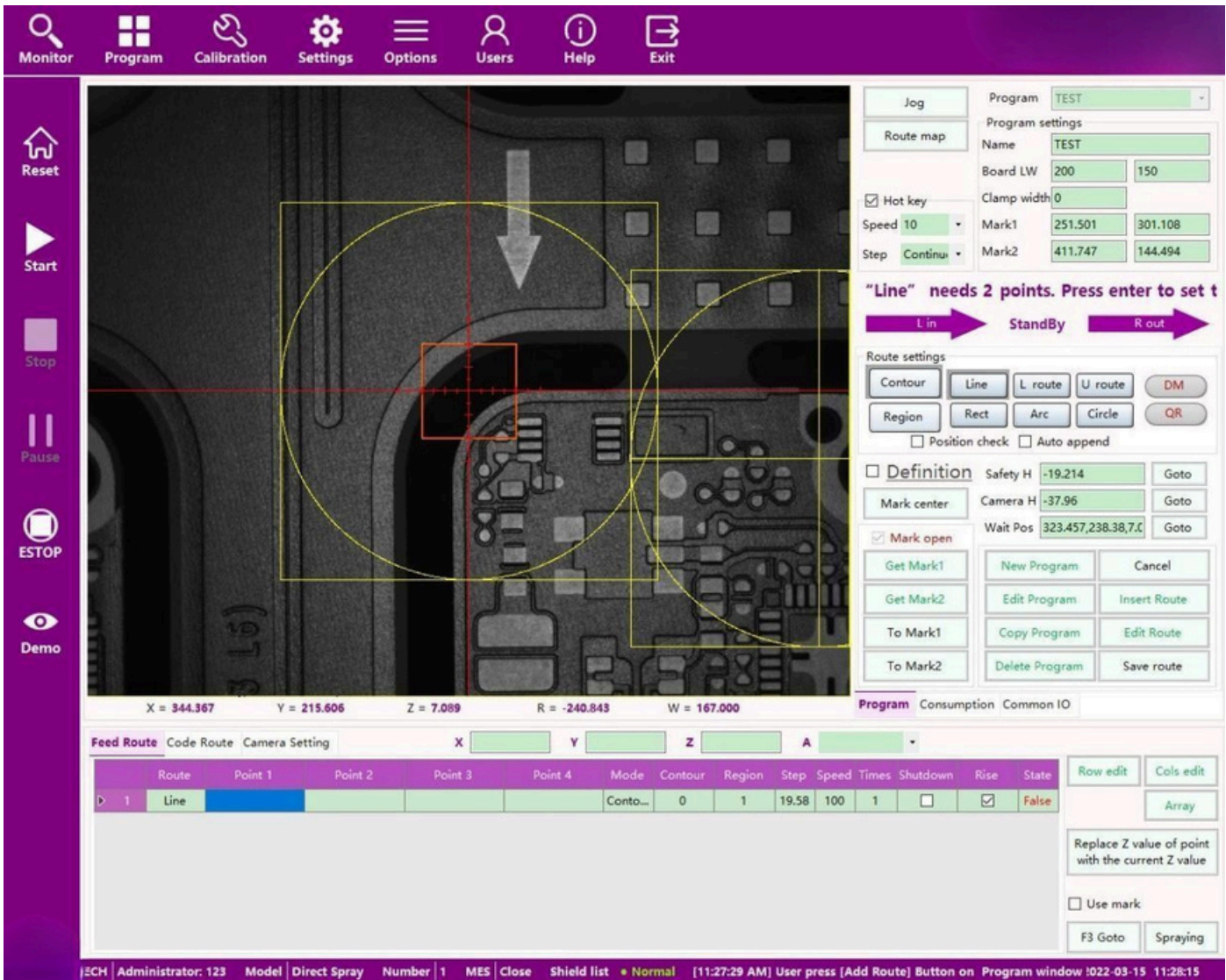

Spray route editing, the system provides 6 types: straight line, L shape, U shape, rectangle, arc, circle

Route type setting;

- 1) Line: At the front and rear positions to be sprayed, press "Enter" to confirm the two points;
- 2) L shape: At the front, middle and rear positions to be sprayed, press "Enter" to confirm the three points;
- 3) U shape: In the upper, lower, left and right positions to be sprayed, press "Enter" to confirm the four points;
- 4) Rectangle: Press "Enter" to confirm the four points at the upper, lower, left and right positions to be sprayed;
- 5) Arc: At the front, middle and rear positions to be sprayed, press "Enter" to confirm the three points
- 6) Circle: Press "Enter" to confirm the three points at the front, middle and rear positions to be sprayed

Various route type rules are shown in the following figure;

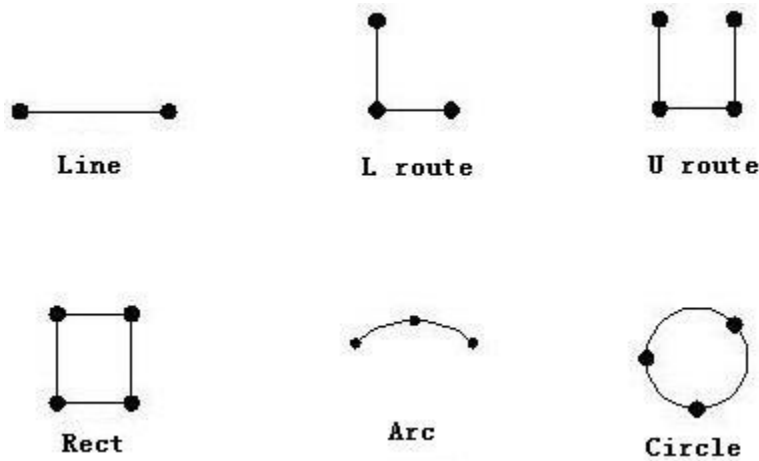

As shown in the figure below, when the setting status is "True", the corresponding route is set, otherwise it is displayed as "False";

Route	Point 1	Point 2	Point 3	Point 4	Mode	Contour	Region	Step	Speed	Times	Shutdown	Rise	State	
1	Line	[344.367,215.6...	[398.677,216.6...			Conto...	0	1	19.58	100	1	<input type="checkbox"/>	<input checked="" type="checkbox"/>	True
2	Line	[387.518,193.4...				Conto...	0	1	19.58	100	1	<input type="checkbox"/>	<input checked="" type="checkbox"/>	False

If you find that the line type is wrong when editing, select the wrong line type, click the correct line type in the following figure, the system will ask whether to change it, click OK.

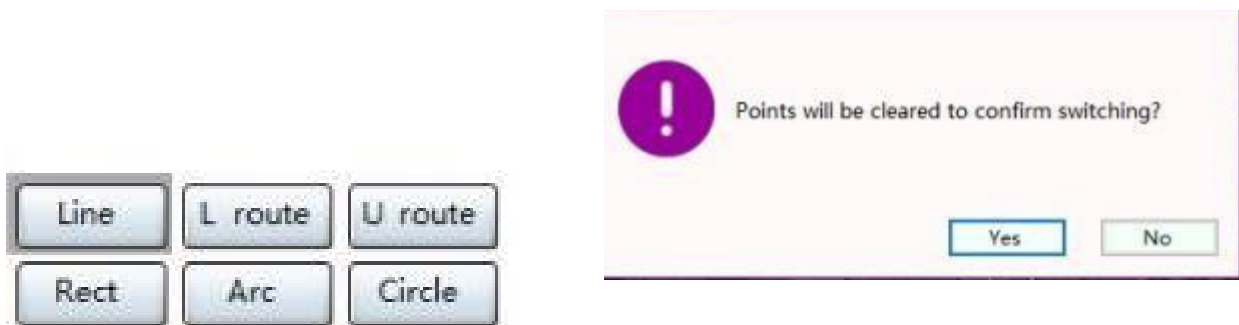

(5) According to differentPCBA,ifyouneeded to scan the code during spraying, click "QR code", move the cameracrosscursorto the position of the code, and press "Enter" to confirm. At this time,thescancodeposition is confirmed, as shown in the figure below.

Route	Position	Group	State
1	DM code [349.193,179.787,-37.96]	0	True
2	DM code [349.193,179.787,-37.96]	0	True

(6) If the sprayed PCBA is a regular polygonal sheet, according to the methods (1) to (5), after setting the path of the first small board in the PCBA , the "array" function can be used.

Select all the spraying paths of the first panel, click "Array", according to the situation shown in the figure below;

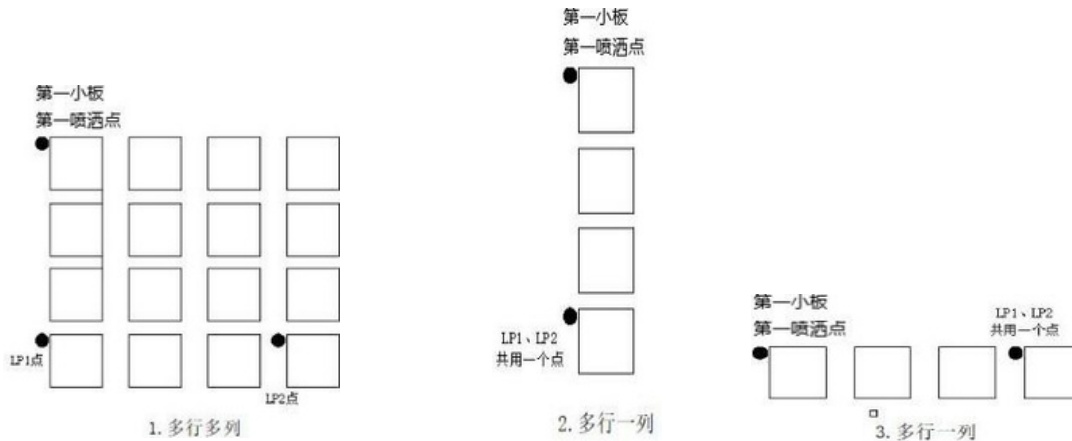

Move the camera cross cursor to the "TLP1" position as shown above, click "LP1", move the camera cross cursor to the "TLP2" position as shown above, click "LP2", and the "Array Window" will pop up. Enter the corresponding number of rows and columns in the window, and click "OK".

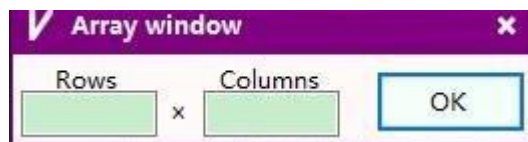

To verify that the spraying paths in the program are correct, select the program to be verified, click "Thumbnail" to view all paths,

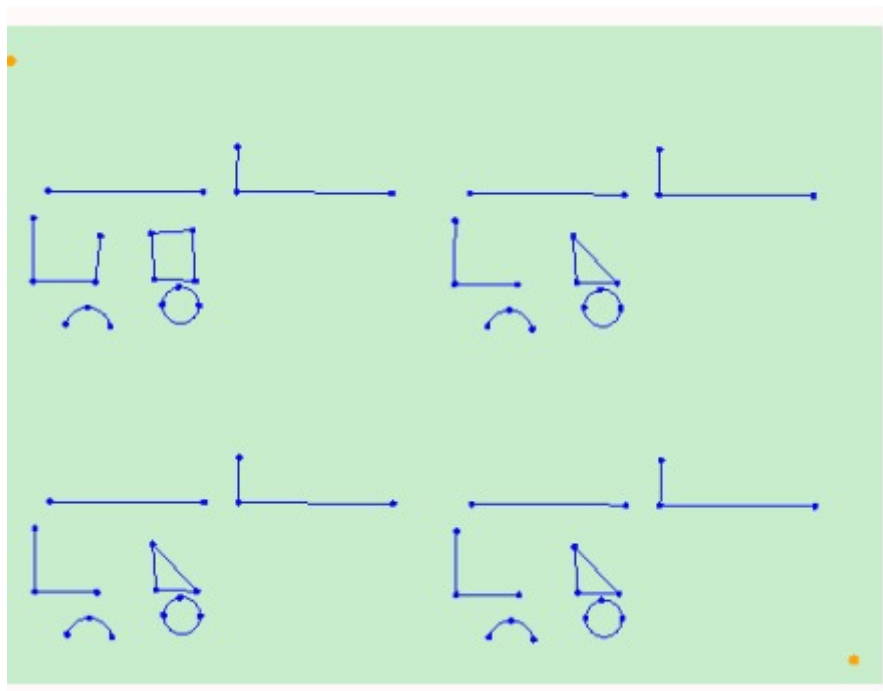

Click "Demo Mode", select the relevant function, and click "Start". In demo mode, "camera mode", "Spraying", "with code reading" and other functions are as follows;

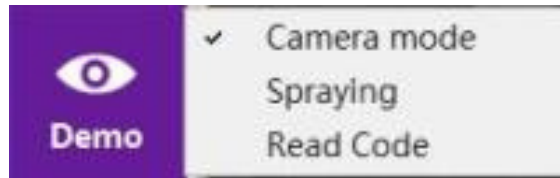

Check "Camera Mode", the camera will display the location of the spray path during simulation;

Check "Spraying", the spindle will simulate spraying at the location of the spraying path;

Check "Read Code", the camera will move to the position to read the code to read the code;

You can check multiple options at the same time or individually, and the device will perform corresponding actions during presentation.

With the demo mode, verify that the program is edited correctly. If any errors are found, click Modify to make changes. At this time, click "Update Route", and the system will perform Mark compensation on all paths according to the modified Mark point deviation. If you do not click, only the modified path will be updated.

III. Mechanical Calibration

The calibration window includes two parts: "machine parameter setting" and "camera parameter setting";

After the equipment is assembled, a mechanical calibration will be done. After the mechanical calibration is completed, it is generally not necessary to recalibrate without disassembly.

1. Click "Calibration Setting", select "Machine Parameter Setting", and the "Calibration Setting Window" will pop up, as shown in the figure below;

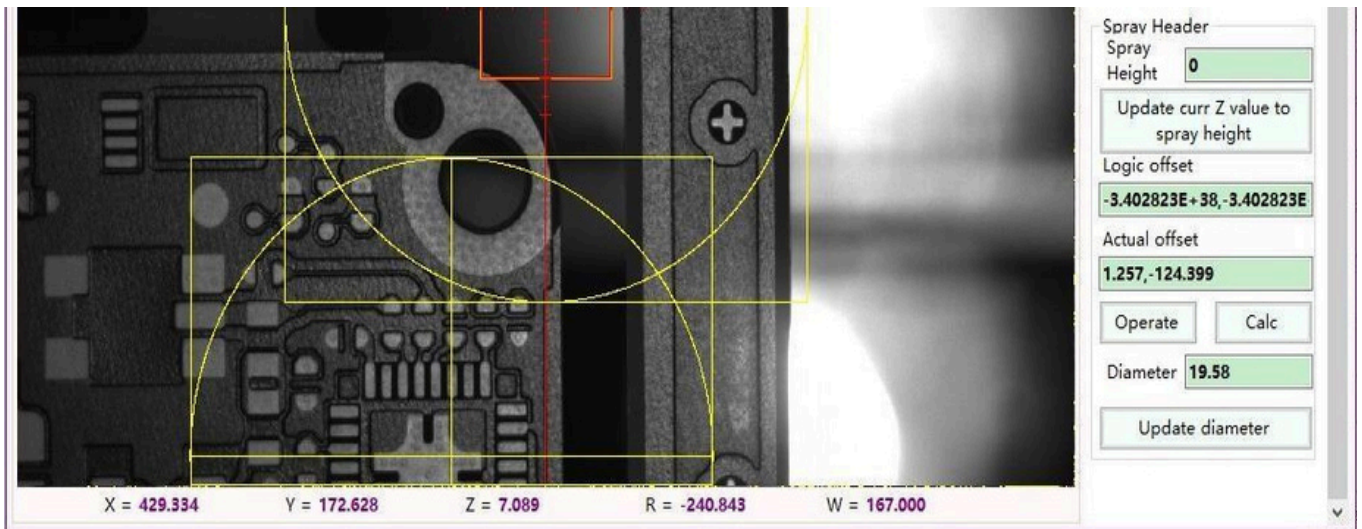
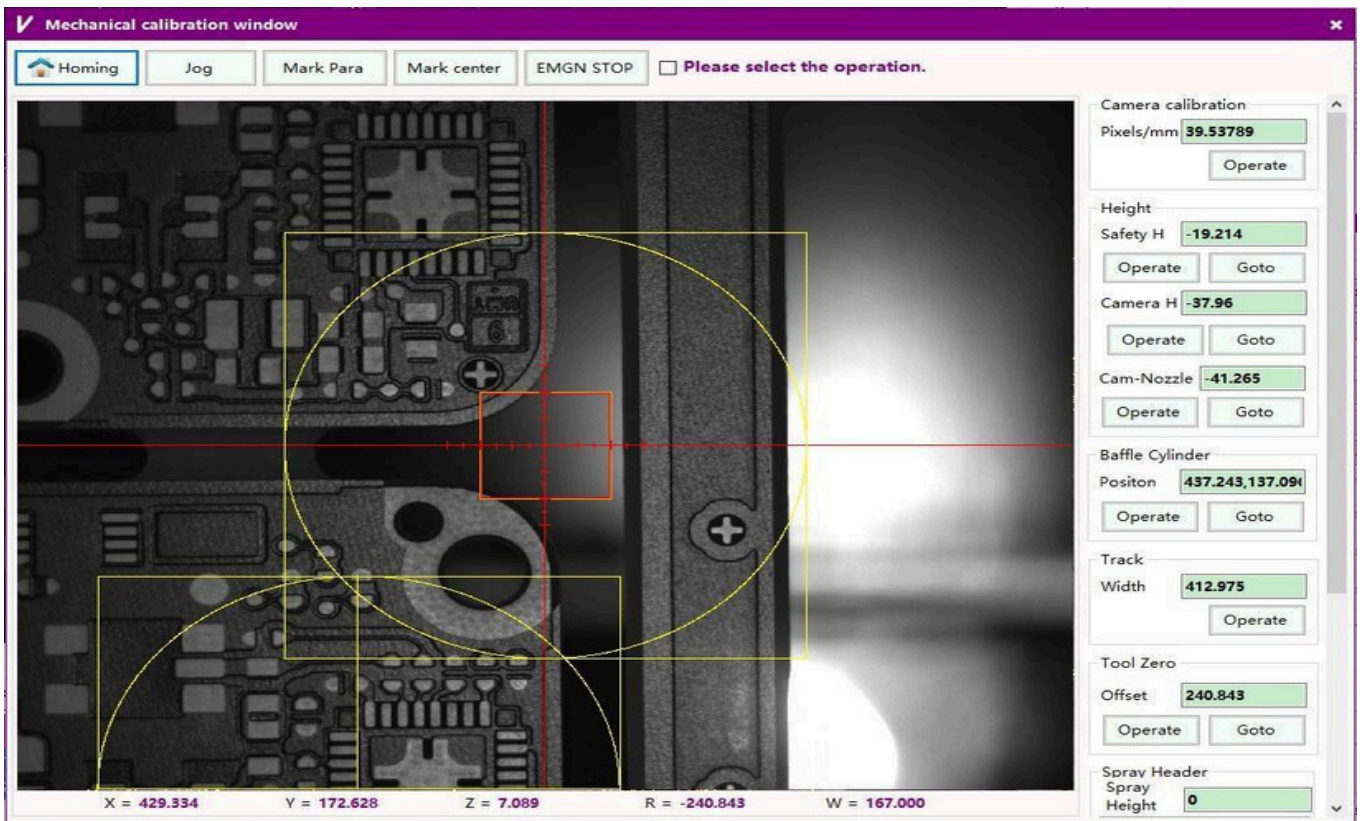

(1) Click "Homing" in the upper left corner of the interface, and each axis of the device will return to the origin;

(2) Camera calibration

① Pixels/mm: Using the camera height that has been set, move the camera cross cursor to the center of the Mark on the PCB board, click "Pixel Calibration", and the camera will take values at the four corners of the Mark;

The system will automatically calculate the pixel value of the current camera.

No need to manually input, the system will automatically add the value in, if re-calibration, the system will prompt whether to replace, click "OK" to complete the camera calibration.

(3) Height Calibration:

- ① Safety H: Set the default safe position of the Z axis during processing, click "Operate", and then click "Get";
- ② Camera H: Call up the shortcut window by pressing "F2", move the camera cross cursor to the Mark center of the PCBA board, and check "Get camera sharpness value", as shown in the following figure:

Please select the operation.

At this point, it will turn into a series of numbers, slowly move the Z axis of the spindle to make the number at the maximum value, click "Operate", and then click "Get";

- ③ Cam-Nozzle : Call up the shortcut window by pressing "F2", move the Z axis so that the nozzle is 10-12cm away from the sprays surface, click "Operate", and then click "Get";

(4) Baffle Cylinder:

- ① Position(Cylinder) : Call up the shortcut window by pressing "F2", move the camera cross center line to align the cylinder of the track baffle, as shown in the figure below

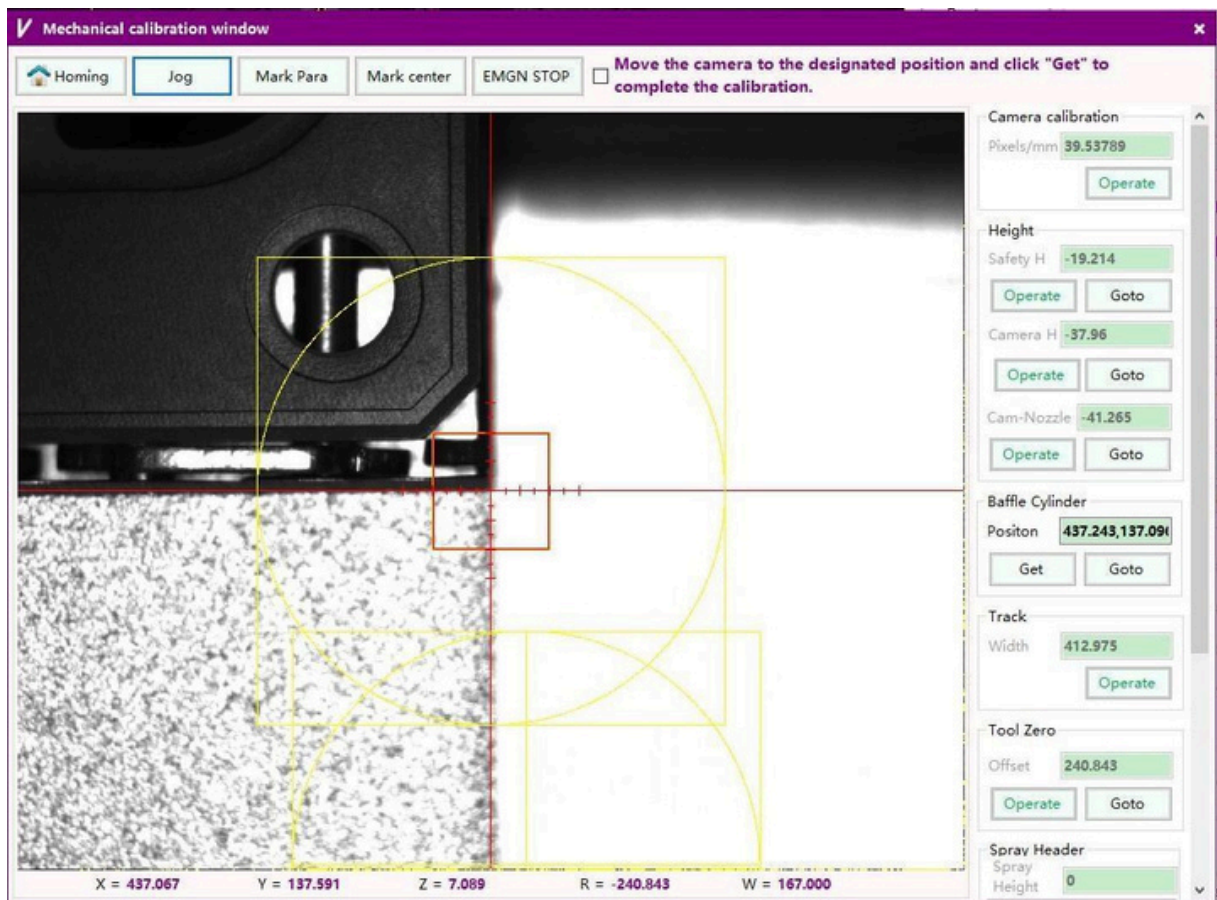

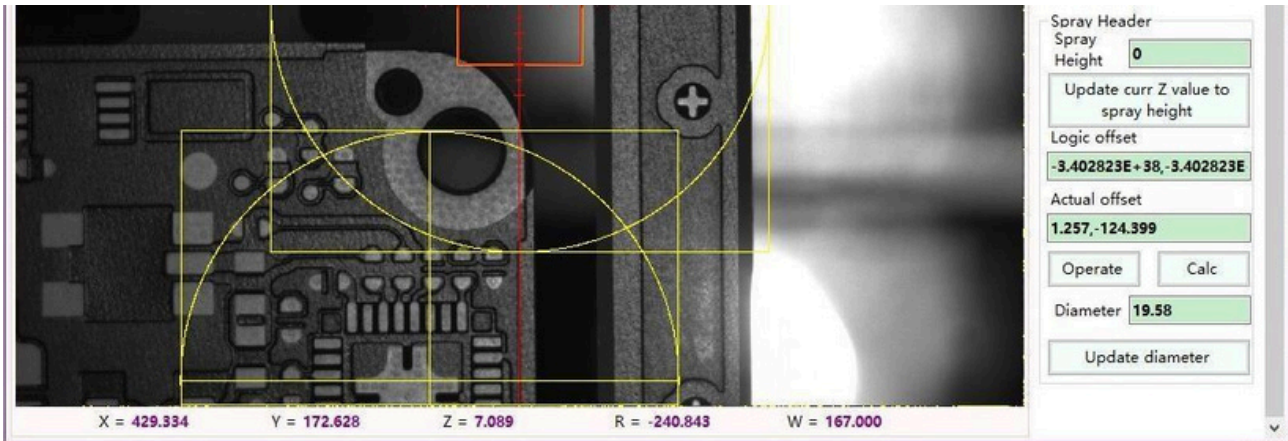

Click "Operate", and then click "Get";

(5) Track calibration:

① Click "Operate", The track automatically returns to the origin, move the camera cross cursor to the inner edge of the track (as shown in the figure below), and click "TLP1";

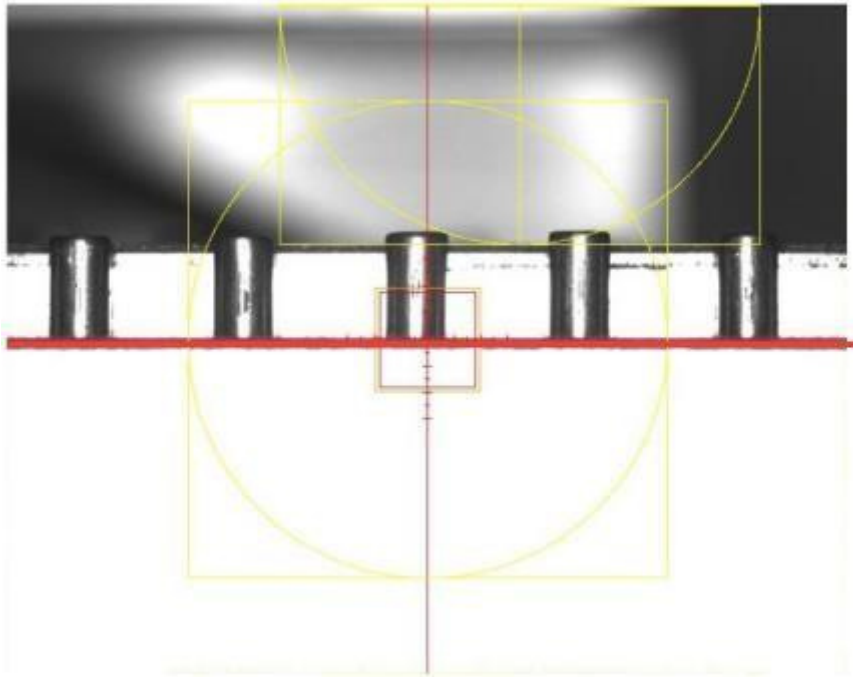

Then move the camera cross cursor to the inner edge of the moving track (as shown in the figure below);

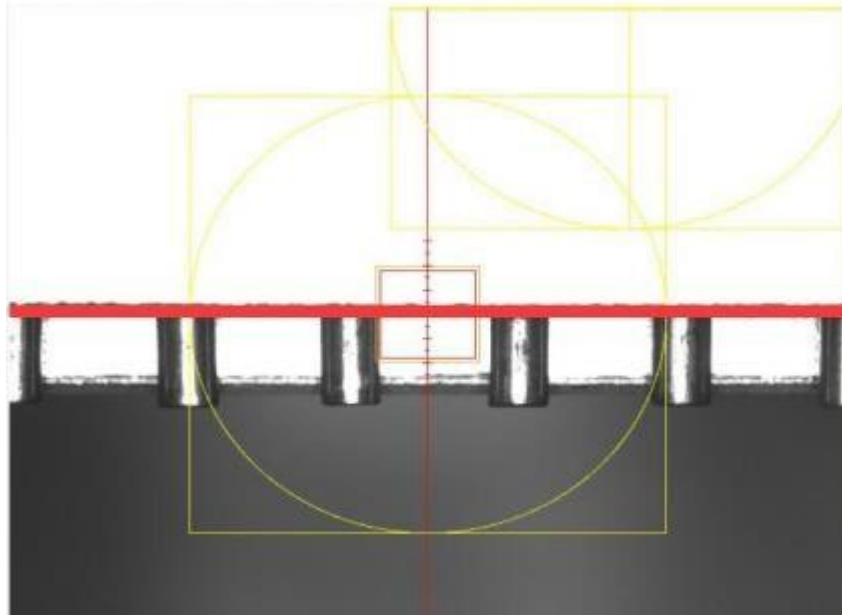

Click "TL P2", the system will pop up a window like as below:

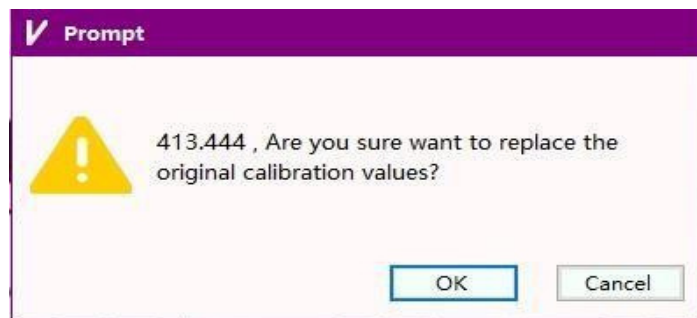

Click "OK", the system will automatically update the value of the total width of the track;

When the track calibration is completed, at the board width position, enter the board width size of a PCBA , and click "Insert Board"; the track will move to the set value position; put the PCB at the front of the track, if the PCB board can be transferred smoothly , the track calibration is completed; otherwise, it needs to be re-calibrated.

(6) Nozzle Angle Calibration

This calibration must be done when the print head has a rotating function. Its purpose is to define the zero-degree angle of the working state of the nozzle. Click "Operate" to manually rotate the nozzle to a custom zero-degree angle through the shortcut key F2 according to the prompt, and then click "Get";

(7) Nozzle Calibration(Spray Header)

① Spray Height : In the next step the height required for the nozzle when offset compensation is performed, click "Update the current Z value to the spray height";

② Offset compensation: This item is divided into logical offset compensation and actual offset compensation. Logical offset compensation refers to the initial value manually input after calculating the center distance between the nozzle and the camera;

while the actual offset compensation is the actual value calculated by the software after the following operations. Click "Operate", the nozzle will spray a point on the PCBA, and move the camera cross cursor to the center of the point. At this time, manually align the camera cross cursor with the center of the point, and click "Get";

③ Diameter (Spray diameter): Click the nozzle diameter manually input the diameter of the nozzle, and then click "update diameter";

2. Click "Calibration Settings", select "Camera Parameter Settings", and the "Camera Parameter Settings Interface" will pop up, as shown in the figure below;

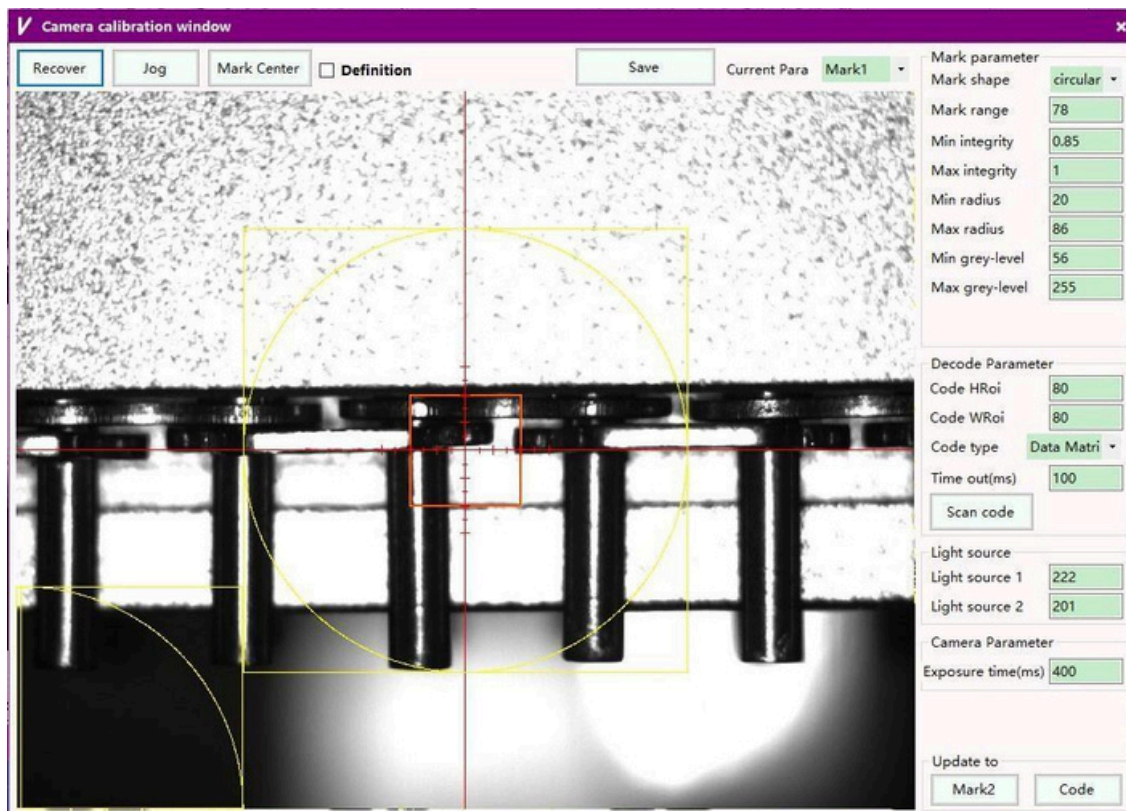

Mark parameter, including "circularity"、"matching" two model, as shown in the figure below;

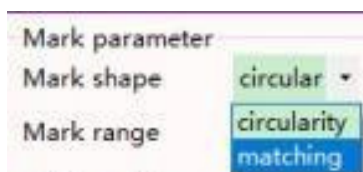

The "circularity" mode is commonly used, and only the "circularity" mode is valid in "Camera Calibration";

When adjusting the "Mark parameter" in the program setting, the parameters at this time will be saved in the selected program. Therefore, when doing mechanical calibration, remember not to open the program setting interface;

(1) In "Current Parameters", select "Mark1", in "Mark Parameters", select "circularity", as shown in the figure below;

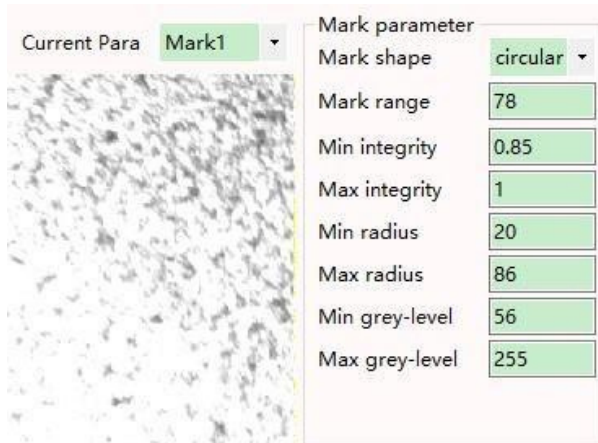

1) Markrange:whensettingthephoto mark,the effectiveareafor d iscrimination;(Note: the unit is in pixels)! ;

2) Minintegrity: AccordingtodifferentMarkpoints,adjustthevalue to achieve the best acquisition effect; (the minimumvalue is 0.1, the larger the value, thehighertheconsistencyrequirementssoftheMarkpoint);

3) Max integrity: This value isa fixedvalue of1;

4) Minradius: Theunitofthisvalueispixel,thevalueof"Camera Calibration"needstobeused,anditisfilledinaccordingtothesizeoftheMark point;

The figurebelow(1)indicatesthat40.53077pixelsrepresent1mm;

As showninFigure(2)below,eachsmallgridofthecameracrosscursor represents 0.5mm;

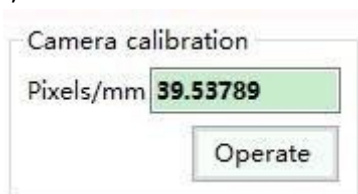

(1)

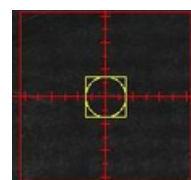

(2)

5) Maxradius: Normallyitistwicethe"minimumradius",whichcan be appropriately adjusted according to the acquisition effect of Mark points;

6) Maxgrey-level\Maxgrey-level : Thisvalueneedstobesetaccording tothecurrentMarkpointandthegrayvaluedisplayedbythecamera;movethemouse cursortotheoutsideoftheMarkedgeandclicktherightmousebuttontodisplay asshowninthefollowingfigure(1),whichis37;movethemousecursortotheMark edge,clicktherightmousebuttontodisplayasshowninthefollowingfigure(2), the display is 255;



(1)



(2)

Therefore, the minimumgrayvalueistheoretically37(actually, in order to allow the camera to betterobtaintheMark,the minimumgrayvalue is appropriately increased); the maximumgrayvalueistheoretically 255;

When the above parameters are set, the edge of the Mark point is surrounded by a red circle (the yellow circle is the size of the nozzle), and the camera cross cursor is just in the center of the Mark point; the obtained effect is shown in the figure below;

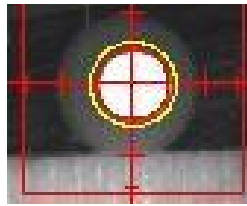

In the red square frame, move the camera cross cursor away from the center of the mark point, and then click "to the center of the mark", if it can be captured well, it means that the mark parameters have been set;

(2) In "Mark Parameters", select "matching", the display is as shown below;

Mark parameter	
Mark shape	matchir
Mark range	78
Model HRoi	50
Model WRoi	50
Model Score	0.85
Min contrast	23
Max contrast	50
Component size	200
Auto get	

Mark Shape: "matching" mode is used when the mark is non-circular; move the camera cross cursor to the center of the mark (manual centering is required), click "automatic get", and the system will automatically acquire a set of data according to the situation of the mark;

Mark range: In the range of 50-180, the larger the value, the larger the effective recognition area

1) Model HRoi(radius) (height): The unit of this value is pixel, set the search range of the matching image (equivalent to the height of the green box), as shown in the following figure;

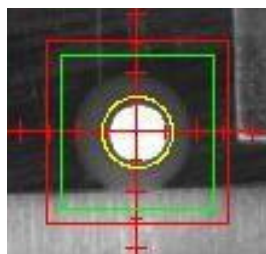

2) Model WRoi raduis (weight): The unit of this value is pixel, which sets the search range of matching images (equivalent to the width of the green box);

3) Model Score: The larger this value is, the higher the consistency requirements for matching images are; (the value range is 0.1-1)

4) Min contrast: The similarity of the pairing, the camera can identify

the minimum contrast threshold of the Markpoint;itisdeterminedtobesuccessful within the range of the minimum and maximumcontrast;

5) Max contrast: The similarityofthepairing,thecameraanrecognize the maximum contrast threshold of the Mark point, and the contrast of the current image as the Mark point is within the minimumandmaximumrange,it isjudgedtobe successful;

6) Component size : When the aboveparameterscannotobtainthebestimaging, adjusting this value can improve the effecttoacertainextent;

When the above parameters are set,it isbestfortheMarkpointonlytobe surrounded by a green circle;

(3) Decode Parameter

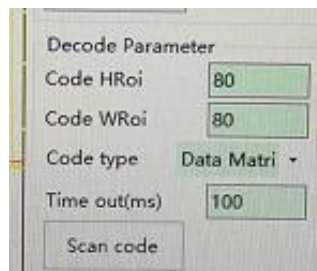

1) DecodeHRoi(Height): Theunitofthisvalueispixel,whichrefersto the height of the yellow box of the decoding search range;

2) DecodeWRoi(Weight): Theunitofthisvalueispixel,whichrefersto the width of the yellow box in the decoding search range;

3) Codetype: Thedecodabletypesaredividedintotwotypes:DMcodeand QR code;

4) Timeout(ms): Itmeansthatifthedecodingcannotbesuccessfulwithin the set time range, the software will alarm;

5) Scancode: Clickthisbuttontodecodeandtesttheimageofthecurrent camera;

(4) Light source

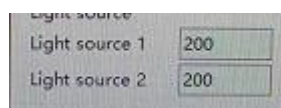

1) Light1source : Brightnessadjustmentoftheredlightsource.According todifferentplates,adjustthebrightnessstoachievethethebestimagingeffect;(the adjustmentrangeis0-250,thelargerthevalue,thebrighter);

2) Light2source: Brightnessadjustmentforwhitelightsources.According to differentplates,adjustthebrightnessstoachievethethebestimagingeffect;(the adjustmentrangeis0-250,thelargerthevalue,thebrighter);

(5) CameraParameter

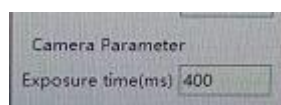

Exposuretime:Accordingtodifferent plates,adjust the value to achieve the bestimagingeffect;(theminimumvalue is 0,thelarger the value, the brighter);

Updateto:Updatethecurrent parametersto "Mark2" or "Code";

Chapter 3: Equipment Circuit Diagram

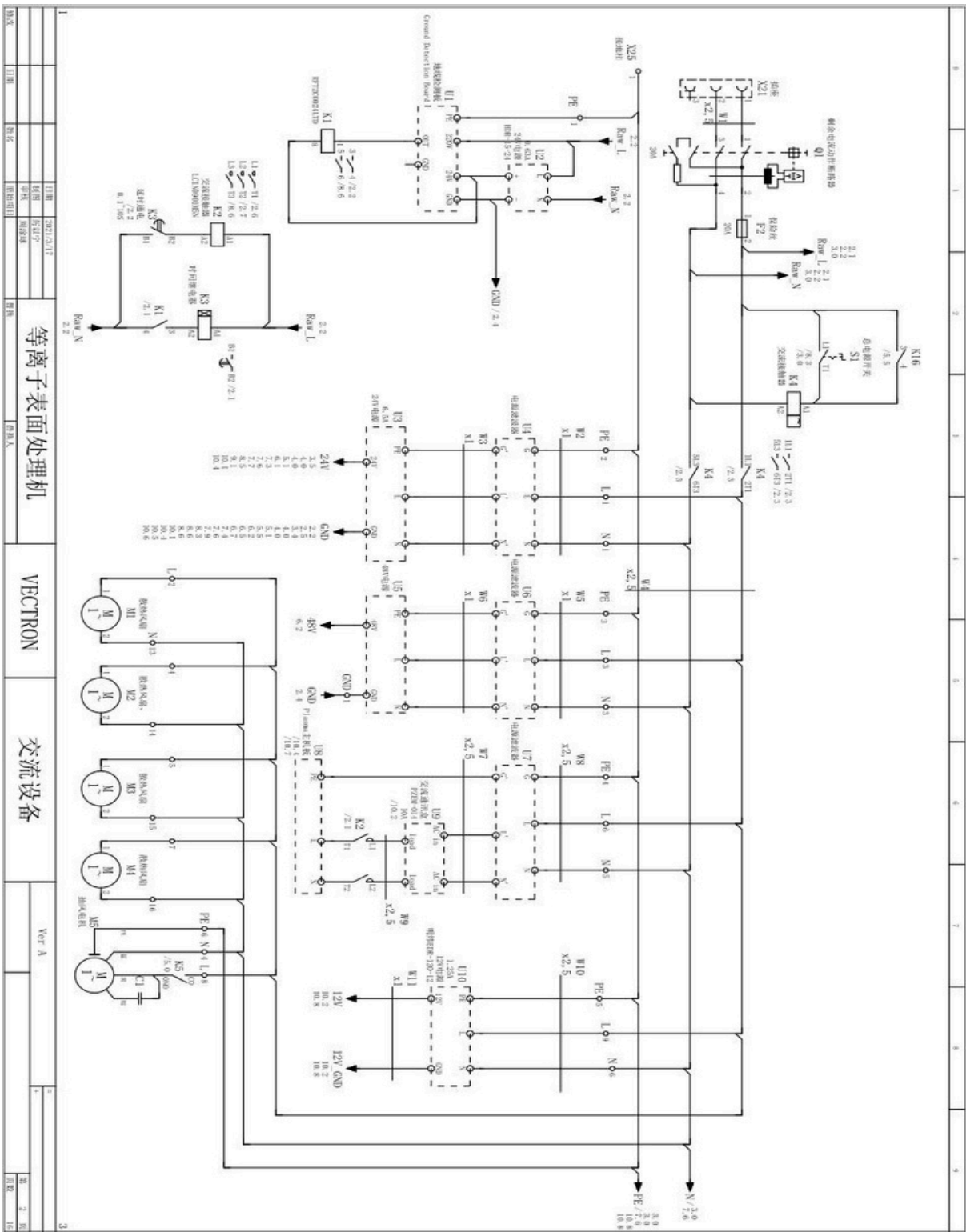

图号	日期	姓名	比例	1:1	2021/3/17	设计	审核	批准	日期	姓名
等离子表面处理机										
VECTRON										
交流设备										
Ver A										
										第 2 页
										共 2 页

AC power supply diagram

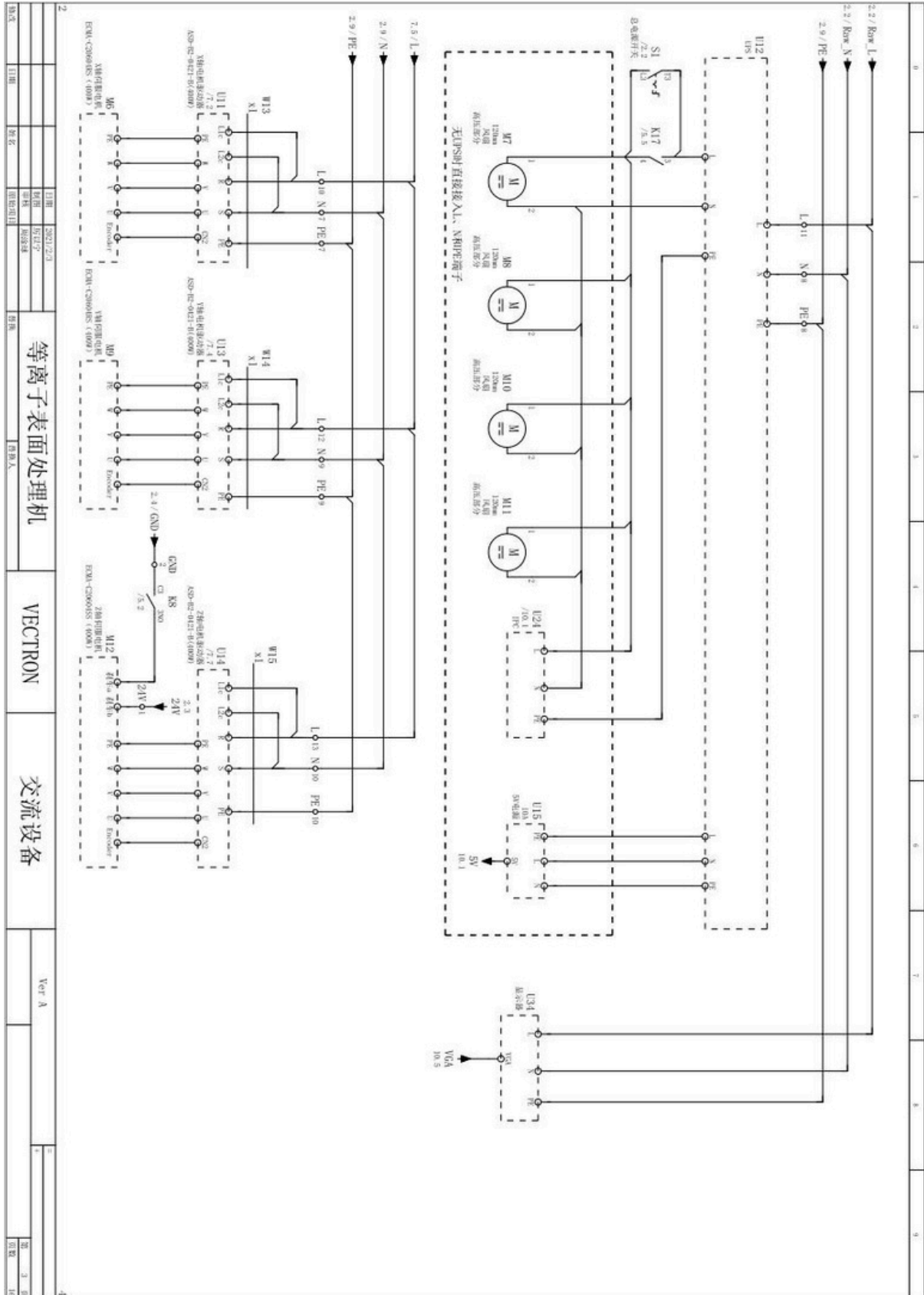

AC equipment power supply diagram

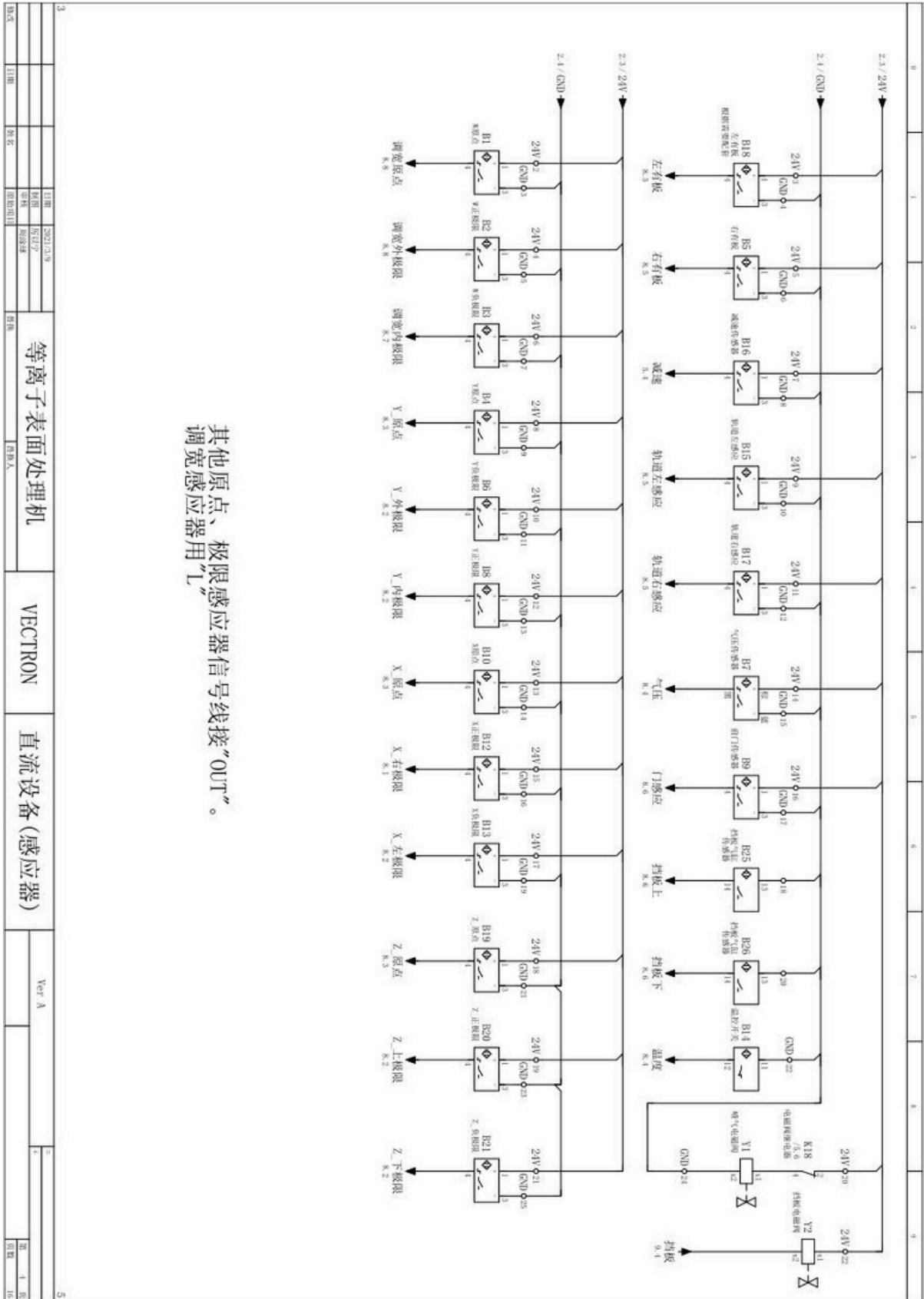

其他原点、极限感应器信号线接“OUT”。
调宽感应器用“L”。

图号	1100	图名	等离子表面处理机	VECTRON	直流设备(感应器)	Ver A
比例		日期	2021/3/9			
审核		制图	陈国栋			
校对		审核				
设计		日期				
制图		日期				
审核		日期				
设计		日期				
制图		日期				
审核		日期				
设计		日期				
制图		日期				
审核		日期				
设计		日期				
制图		日期				
审核		日期				
设计		日期				
制图		日期				
审核		日期				
设计		日期				
制图		日期				
审核		日期				
设计		日期				
制图		日期				
审核		日期				
设计		日期				
制图		日期				
审核		日期				
设计		日期				
制图		日期				
审核		日期				
设计		日期				
制图		日期				
审核		日期				
设计		日期				
制图		日期				
审核		日期				
设计		日期				
制图		日期				
审核		日期				
设计		日期				
制图		日期				
审核		日期				
设计		日期				
制图		日期				
审核		日期				
设计		日期				
制图		日期				
审核		日期				
设计		日期				
制图		日期				
审核		日期				
设计		日期				
制图		日期				
审核		日期				
设计		日期				
制图		日期				
审核		日期				
设计		日期				
制图		日期				
审核		日期				
设计		日期				
制图		日期				
审核		日期				
设计		日期				
制图		日期				
审核		日期				
设计		日期				
制图		日期				
审核		日期				
设计		日期				
制图		日期				
审核		日期				
设计		日期				
制图		日期				
审核		日期				
设计		日期				
制图		日期				
审核		日期				
设计		日期				
制图		日期				
审核		日期				
设计		日期				
制图		日期				
审核		日期				
设计		日期				
制图		日期				
审核		日期				
设计		日期				
制图		日期				
审核		日期				
设计		日期				
制图		日期				
审核		日期				
设计		日期				
制图		日期				
审核		日期				
设计		日期				
制图		日期				
审核		日期				
设计		日期				
制图		日期				
审核		日期				
设计		日期				
制图		日期				
审核		日期				
设计		日期				
制图		日期				
审核		日期				
设计		日期				
制图		日期				
审核		日期				
设计		日期				
制图		日期				
审核		日期				
设计		日期				
制图		日期				
审核		日期				
设计		日期				
制图		日期				
审核		日期				
设计		日期				
制图		日期				
审核		日期				
设计		日期				
制图		日期				
审核		日期				
设计		日期				
制图		日期				
审核		日期				
设计		日期				
制图		日期				
审核		日期				
设计		日期				
制图		日期				
审核		日期				
设计		日期				
制图		日期				
审核		日期				
设计		日期				
制图		日期				
审核		日期				
设计		日期				
制图		日期				
审核		日期				
设计		日期				
制图		日期				
审核		日期				
设计		日期				
制图		日期				
审核		日期				
设计		日期				
制图		日期				
审核		日期				
设计		日期				
制图		日期				
审核		日期				
设计		日期				
制图		日期				
审核		日期				
设计		日期				
制图		日期				
审核		日期				
设计		日期				
制图		日期				
审核		日期				
设计		日期				
制图		日期				
审核		日期				
设计		日期				
制图		日期				
审核		日期				
设计		日期				
制图		日期				
审核		日期				
设计		日期				
制图		日期				
审核		日期				
设计		日期				
制图		日期				
审核		日期				
设计		日期				
制图		日期				
审核		日期				
设计		日期				
制图		日期				
审核		日期				
设计		日期				
制图		日期				
审核		日期				
设计		日期				
制图		日期				
审核		日期				
设计		日期				
制图		日期				
审核		日期				
设计		日期				
制图		日期				
审核		日期				
设计		日期				
制图		日期				
审核		日期				
设计		日期				
制图		日期				
审核		日期				
设计		日期				
制图		日期				
审核		日期				
设计		日期				
制图		日期				
审核		日期				
设计		日期				
制图		日期				
审核		日期				
设计		日期				
制图		日期				
审核		日期				
设计		日期				
制图		日期				
审核		日期				
设计		日期				
制图		日期				
审核		日期				
设计		日期				
制图		日期				
审核		日期				
设计		日期				
制图		日期				
审核		日期				
设计		日期				
制图		日期				
审核		日期				
设计		日期				
制图		日期				
审核		日期				
设计		日期				
制图		日期				
审核		日期				
设计		日期				
制图		日期				
审核		日期				
设计		日期				
制图		日期				
审核		日期				
设计		日期				
制图		日期				
审核		日期				
设计		日期				
制图		日期				
审核		日期				
设计		日期				
制图		日期</				

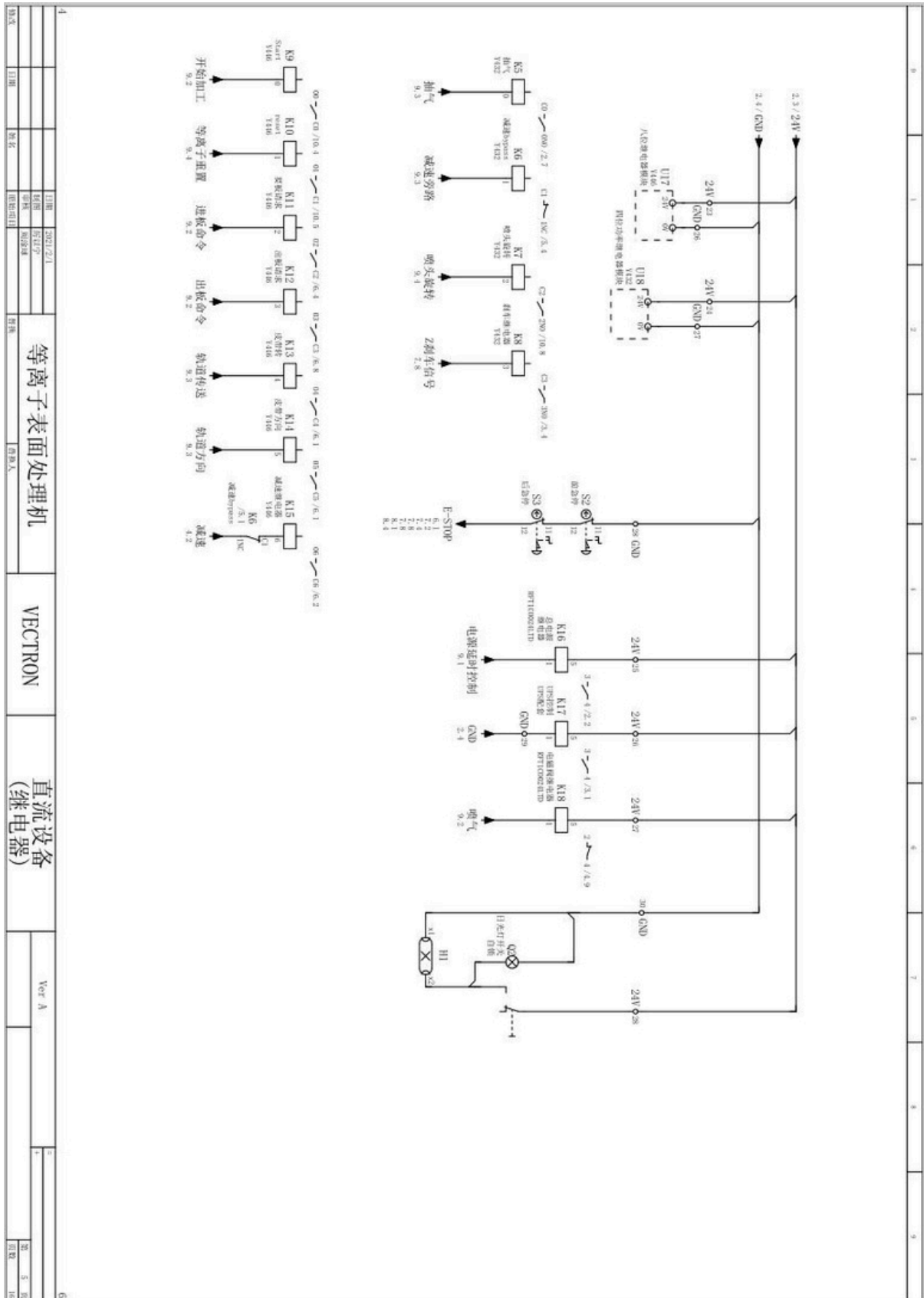

DC equipment power supply diagram (relay)

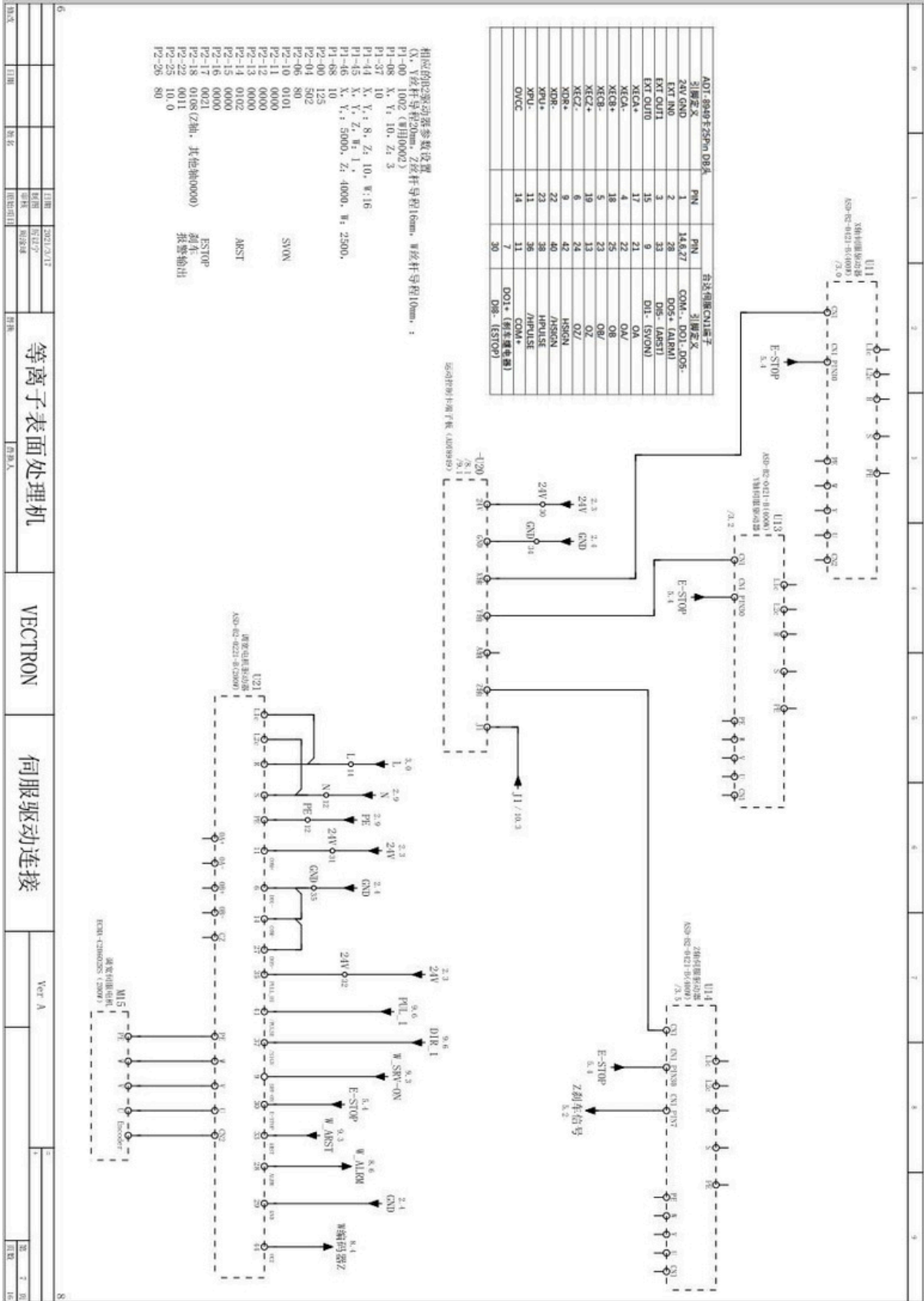

Servo drive connection wiring diagram

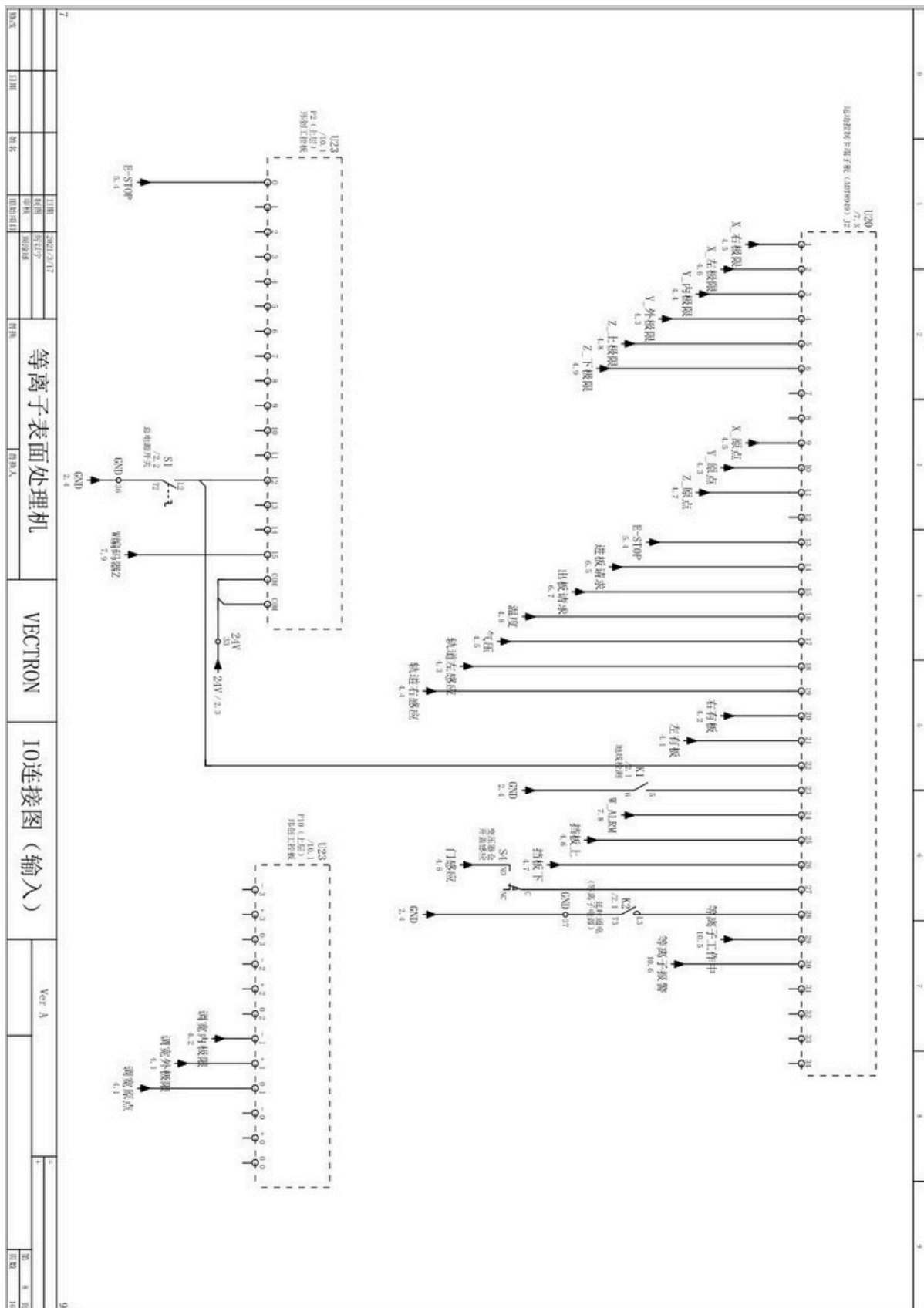

IO Connection Diagram (Input)

Chapter IV: Troubleshooting

I. Easy troubleshooting

1. The power supply does not turn on

- Check if there is a power input.
Confirm whether the switch of the distribution box is

-

powered on or whether the switch is broken.

- Confirm that the emergency stop of the device is turned off and that the emergency stop switch of the device is dismissed.

2. The equipment shakes violently during processing

- Confirm that the four fixed foot cups of the machine are locked and that each axis runs smoothly.

3. Crash to limit switch

- The X, Y axis of the nozzle triggers to the limit switch, the equipment will issue a warning, at this time, you can press the emergency stop switch, manually remove the nozzle.

4. Air pressure alarm

- The equipment has certain requirements for air pressure, such as unstable air pressure, which will cause damage to Plasma, the equipment will issue a warning and stop running, and the air circuit fault needs to be investigated.

(Plasma working pressure is 0.18-0.27MPa).

5. The conveyor belt does not move

- If the conveyor belt does not move, it is necessary to check whether the conveyor belt preload is too large to cause skidding, or the conveyor belt preload is not enough, causing the active wheel friction to be insufficient to drive the belt to run.

II. Machine maintenance

(1) Every working day, the dirt of the equipment and guide rail must be cleaned, so that the equipment is kept clean, and the air source and power supply must be turned off when leaving work;

(2) If you leave the machine for a long time, turn off the power to prevent non-professionals from operating;

(3) Pay attention to whether there is lubricating oil on the surface of the X and Y guide rails and screws of the equipment to keep them well lubricated! It is recommended that the inspection period is one month, but it needs to change depending on the frequency of use of the equipment, and physical and chemical grease (Lithium Grease) can be used, which has waterproof and heat resistance characteristics.

(4) For plasma generator electrode maintenance, it is recommended to clean the electrode surface with polishing cotton once every two months.

III. Air purification maintenance

This equipment will produce a large amount of ozone during the working process, ozone has a strong bactericidal effect, studies have shown that ozone can kill more than 99% of the killing propagules in 5 minutes; at the same time, ozone also plays a role in deodorizing purposes, many indoor air purifiers to the principle of strong oxidation of ozone, Oxidize the organic matter in the air to achieve the purpose of purifying the air.

Air filter principle: The carbon method filters the exhaust gas, which can effectively purify various effective substances and make the ozone concentration reach a reasonable level。

1. Primary filter cotton, the general use cycle is 1-2 months;
2. Medium efficiency filter element, the general use cycle is 3-6 months;
3. Activated carbon filter cotton, the general use cycle is 6-12 months;

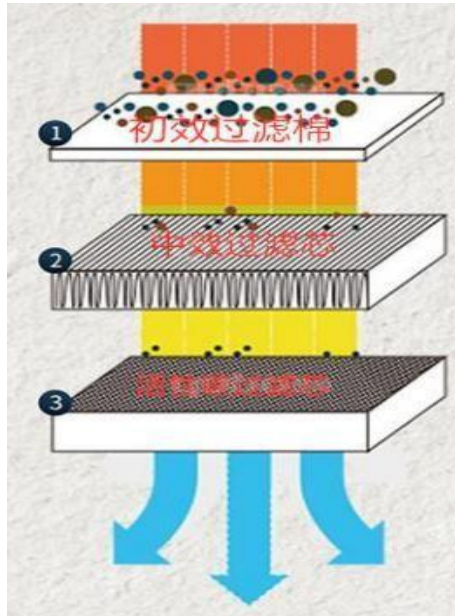

The above replacement cycle, depending on the operating time of the equipment, when it is found that the ozone smell in the production process is relatively heavy, the above filter element needs to be replaced.